

iCt90M/CU60A-Pro



KEY FEATURES

iCt90M/CU60A-Pro delivers 6MP high-resolution imaging with stable performance and advanced ISP features. Its ultra-low power, low heat, and USB power supply ensure reliable operation even in harsh industrial environments

- USB 3.0 interface, 5 Gbps theoretical data transfer bandwidth, USB-powered
- Supports gamma, LUT, denoise, sharpen, color tune
- Compatible with USB3 Vision protocol and GenICam standard
- Compact design with four-side mounting support, ideal for tight spaces and flexible system integration.

TYPICAL APPLICATIONS



Defect Detection

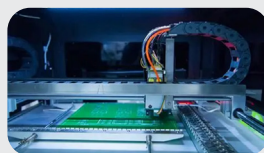

Surface Patch Detection

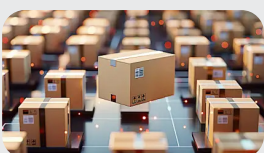

Logistics Sorting



Visual Positioning

► IMAGE SPECIFICATION

Model	iCt90MU60A-Pro	iCt90CU60A-Pro
Resolution	3072 × 2048	
Frame Rate	60 fps	
Sensor	IMX178 (1/1.8"CMOS)	
Pixel Size	2.4 × 2.4 μm	
Mono/ Color	Mono	Color
Bit Depth	12	
Shutter Type	Rolling	
SNR	41.4 dB	
Dynamic Range	71.7 dB	
Image Format	Mono8/10/10Packed/ Mono12/Mono12Packed	Mono 8/10/12, Bayer RG 8/10/10Packed/12 /12Packed,YUV422_8_ UYVY,YUV422_8,RGB8,BGR8
Binning	off, 1×2, 2×1, 2×2, 1×4, 4×1, 2×4, 4×2, 4×4, 3×3	
ROI	Support	
Flip X	Support	
Flip Y	Support	
Gain	1 ~ 32X	
Gamma	LUT Range: 0 to 3.99998	
Exposure Time	25 μs ~ 2.5 sec	
Image Acquisition Mode	Software Trigger, Hardware Trigger, Free Run	
SPC	Support	
Configuration Channel	Supports saving 3 sets of user-defined configurations	
Buffer	256MB	

► CONNECTIVITY

Interface	USB 3.0
GPIO	6-pin Hirose connector: 1 opto-isolated input, 1 opto-isolated output, 1 configurable non-isolated input/output
Power Supply	USB or 9-24V DC (via Hirose)
Power Consumption	2.7W (USB3.0)
Lens Mount	C-Mount

iCt90M/CU60A-Pro

► SPECTRAL RESPONSE

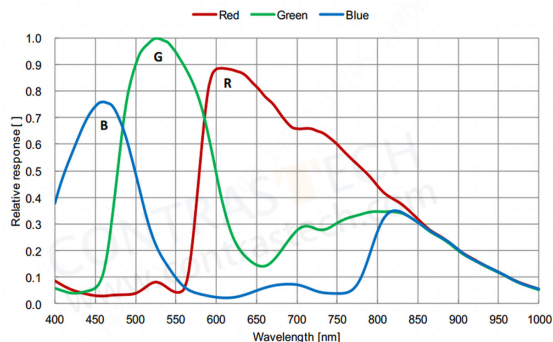
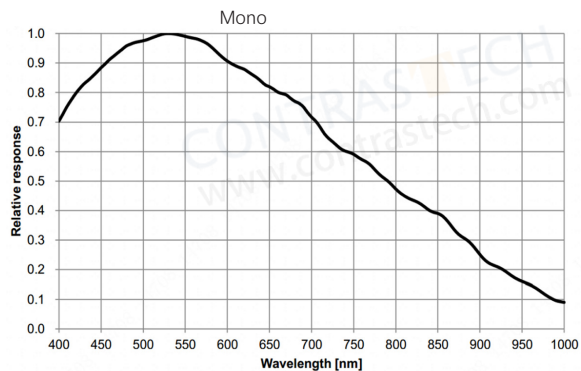

► ENVIRONMENT

Storage Temperature	-30°C ~ +80°C
Operating Temperature	-30°C ~ +50°C

► DIMENSIONS

Size	29×29×30 mm (85g) (excluding lens mount and rear port interface)
------	---

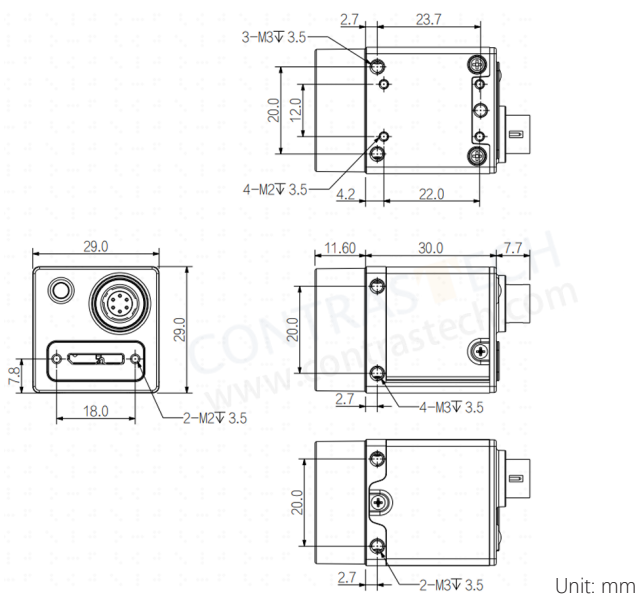

FOR MORE INFORMATION CONTACT



✉ market@contrasttech.com

☎ 86-571-89712238

🌐 www.contrasttech.com

