

LEO Series CoaXPress Area Scan Camera User Manual

V2.4.9, Sep. 2024

Preface

Purpose

This Manual is a basic description of LEO series CoaXPress Area Scan Cameras, which mainly includes the product description, quick installation guide and frame grabber operation guide. This manual may be updated due to product upgrades or other reasons. If you need, please contact the sales engineer for the latest version of this manual.

Copyright ©2023
Hangzhou ConrasTech Co., Ltd.
Tel.: +86 571-89712238
Add.:No. 8 Xiyuan 9th Road, West Lake District Hangzhou Zhejiang 310030 China.

All rights reserved. The information contained herein is proprietary and is provided solely for the purpose of allowing customers to operate and/or service ConrasTech manufactured equipment and is not to be released, reproduced, or used for any other purpose without written permission of ConrasTech.

Disclaimer

The information and specifications described in this manual are subject to change without notice.

Latest Manual Version

For the latest version of this manual, see the Download Center on our web site at: <http://www.conrastech.com/en/service/005001.html>

Technical Support

For technical support, e-mail: support@conrastech.com.

Warranty

To ensure that your warranty remains in force, adhere to the following guidelines:

Do not remove the camera's serial number label

If the label is removed and the serial number can't be read from the camera's registers, the warranty is void.

Prevent ingress or insertion of foreign substances into the camera housing

Prevent liquid, flammable, or metallic substances from entering the camera housing. If operated with any foreign substances inside, the camera may fail or cause a fire.

Avoid electromagnetic fields

Do not operate the camera in the vicinity of strong electromagnetic fields. Avoid electrostatic charging.

Clean with care

Avoid cleaning the sensor if possible.

Handle this camera with care

Do not abuse the camera. Avoid striking, shaking, etc. The camera could be damaged by improper handling.

Read the manual

Read the manual carefully before using the camera.

CHAPTER 1

PRODUCT DESCRIPTION

Product Introduction

LEO series industrial cameras compatible with GigE、USB3.0 and Cameralink data bus standards, support GenICam、USB3 Vision® and GigE Vision®, Smoothly connect with third-party software, like HALCON and Vision Pro, not need for secondary development. LEO series cameras with excellent cost performance and very suitable for various inspections measurement and high-speed imaging applications. This series cameras won customers high praise because its outstanding performance in cellphone and tablet PC screen inspection, LED automatic packaging, defect inspection, and electronic components manufacturing, wafer positioning and other applications.

With this variety of sensors and interfaces, combined with the extensive features offered, LEO series cameras are fit for a wide range of vision applications.

Product Features

- Provides high dynamic range, Signal Noise Ratio (SNR), and high-quality image.
- Supports auto and manual adjustment for gain, exposure time, Look-Up Table (LUT), Gamma correction, etc.
- Adopts CoaXPress interface to transmit data.
- Compatible with CoaXPress Protocol and GenICam Standard.

- * The camera functions may differ by camera models, please refer to actual functions.
- * For acquiring images and setting parameters, via iDatum or SDK based on CoaXPress frame grabber.

Working Principle

The on-board block diagram of CoaXPress port industrial surface array camera is shown in the figure below. After the image sensor receives the image data, it completes the image data processing through the built-in various ISP image processing algorithms, and finally completes the high-speed transmission of the image data through the CoaXPress protocol.

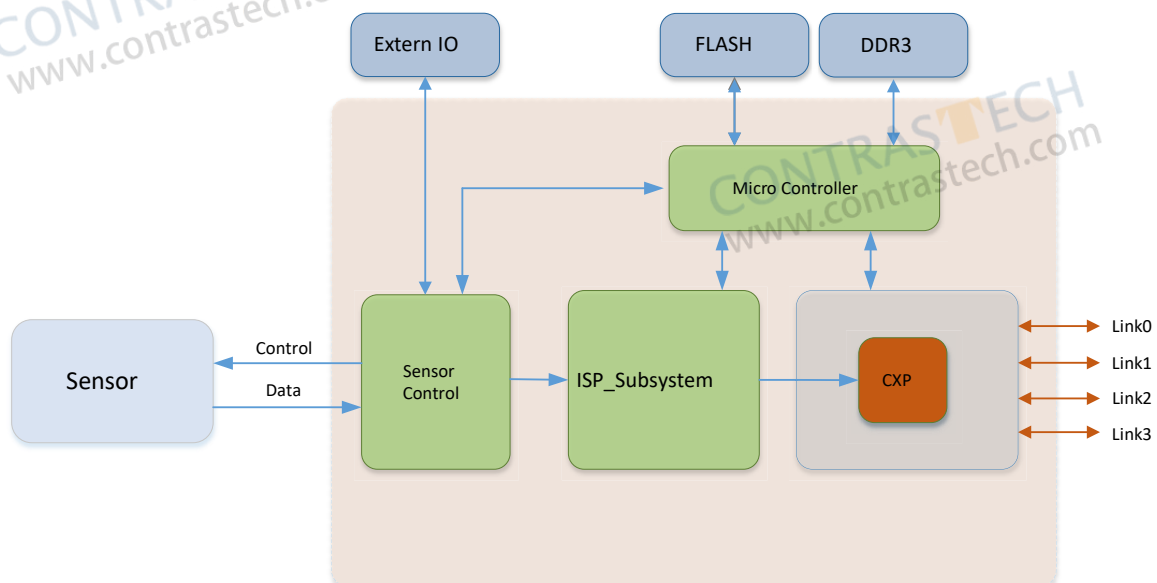

Mechanical Dimensions

The dimensions is in millimeters:

Different models of cameras have different appearances.

The appearance on the back of the industrial camera includes a standard CoaXPress Din port or Micro-BNC port, 12Pin power supply and I/O input ports, a fan, and a camera working status indicator.

Camera Housing and Base Mounting Hole Size(mm):

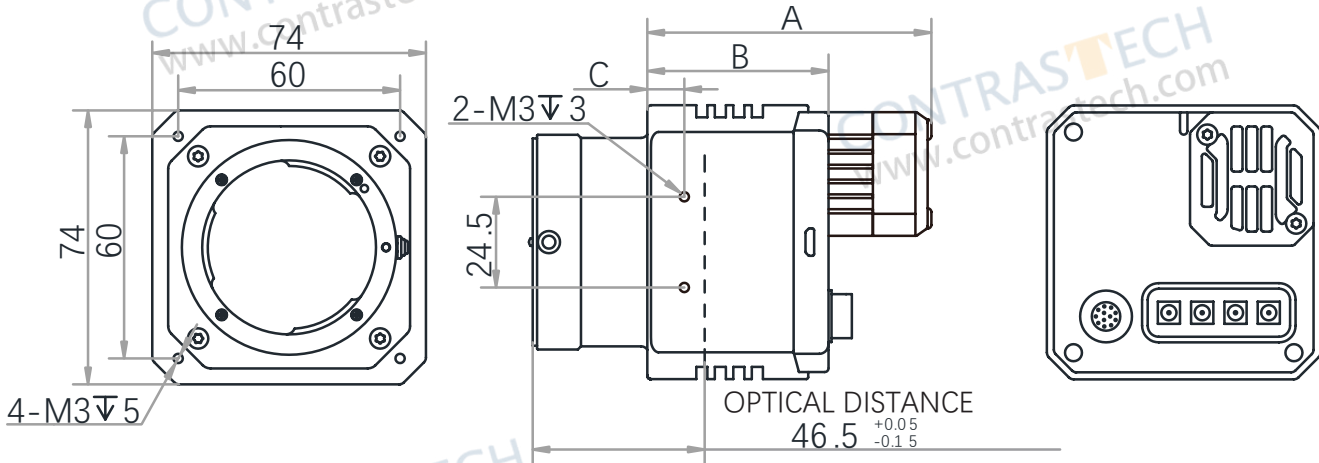

Fig. 1-1: 74 * 74 * A mm mechanical dimensions of the CoaXPress camera with F-Mount, which adopts M3 specification screws.

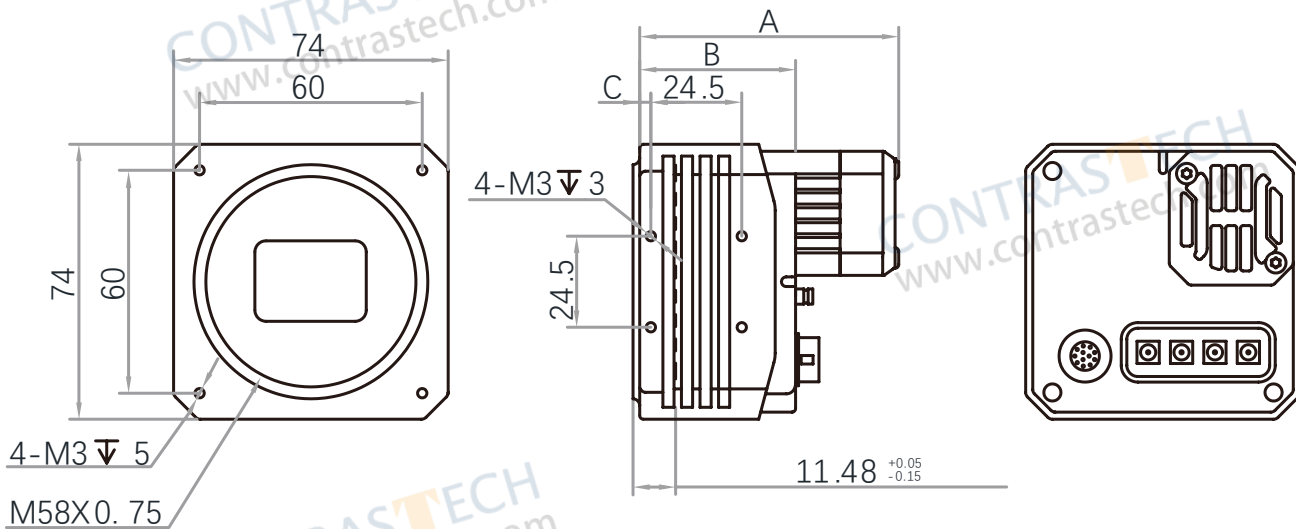

Fig. 1-2: 74 * 74 * A mm mechanical dimensions of the CoaXPress camera with M58, which adopts M3 specification screws.

Model	A (mm)	B(mm)	C(mm)
LEO 31MS-18xm (F-Mount)	75.6	47.8	8.8
LEO 31MS-18xm (M58)	69.8	42	3
LEO 65MG-32xm/xc (F-Mount)	76.4	48.6	10
LEO 65MG-32xm/xc (M58)	70.4	42.6	3.7

Mechanical Dimensions

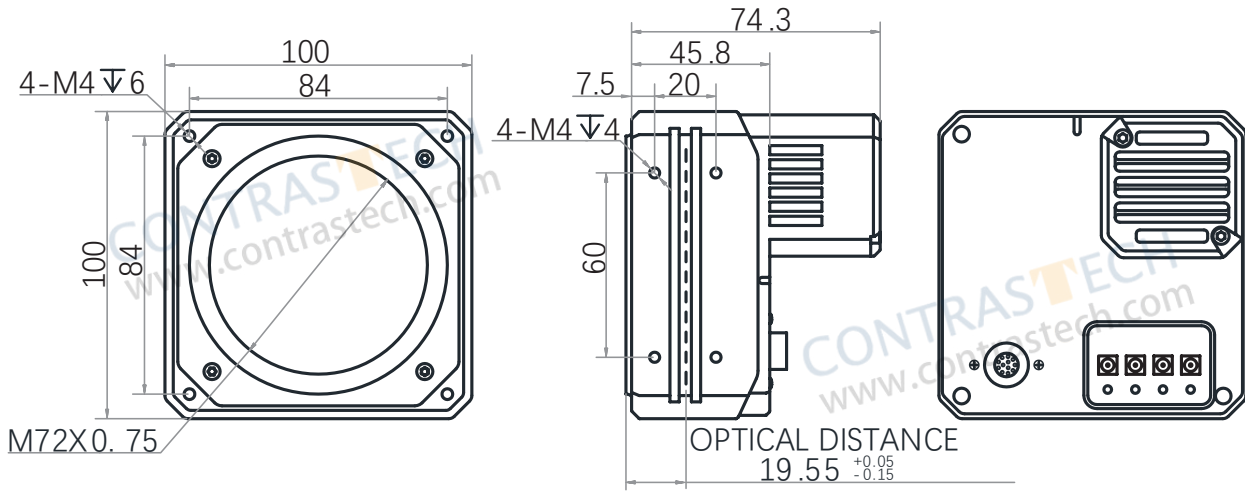

Fig. 1-3: 100 * 100 * 74.3 mm mechanical dimensions of the CoaXPress camera with M72, which adopts M4 specification screws.

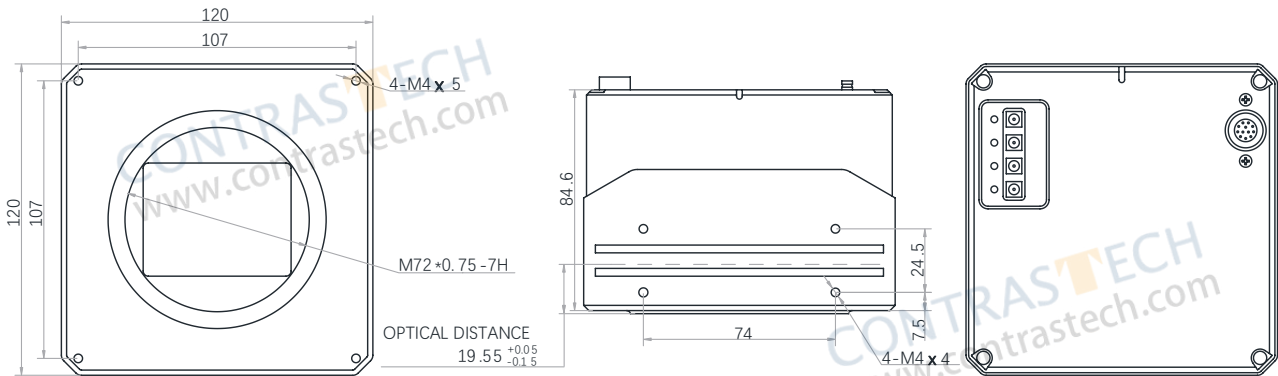

Fig. 1-4: 120 * 120 * 84.6 mm mechanical dimensions of the CoaXPress camera with M72, which adopts M4 specification screws.

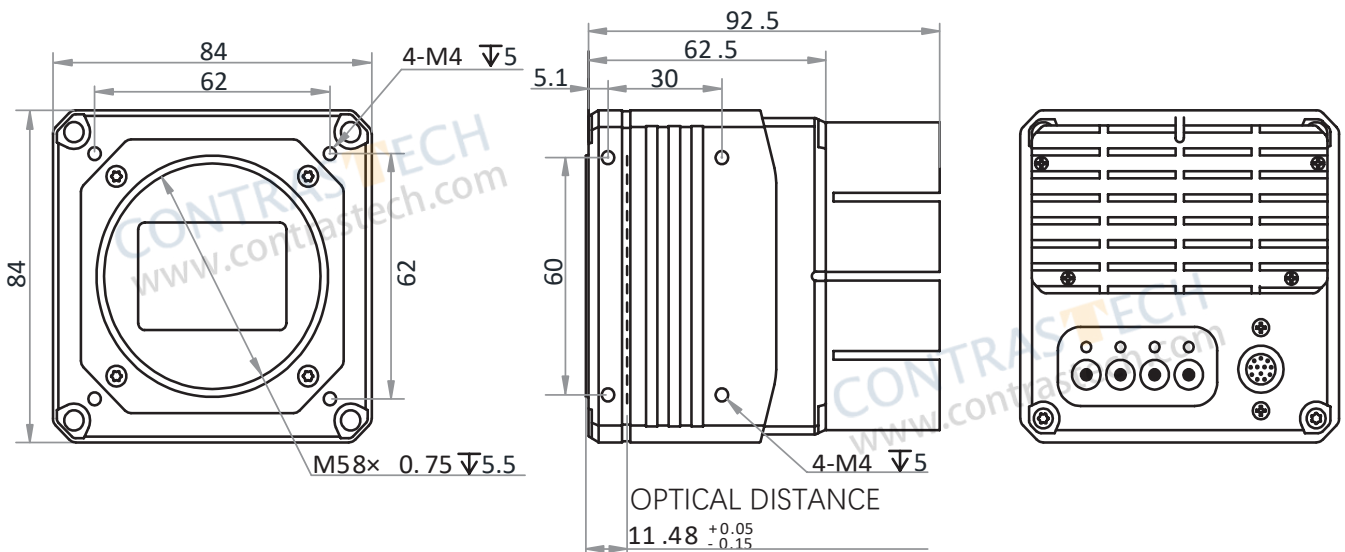

Fig. 1-5: 84 * 84 * 92.5 mm mechanical dimensions of the CoaXPress camera with M58, which adopts M4 specification screws.

Mechanical Dimensions

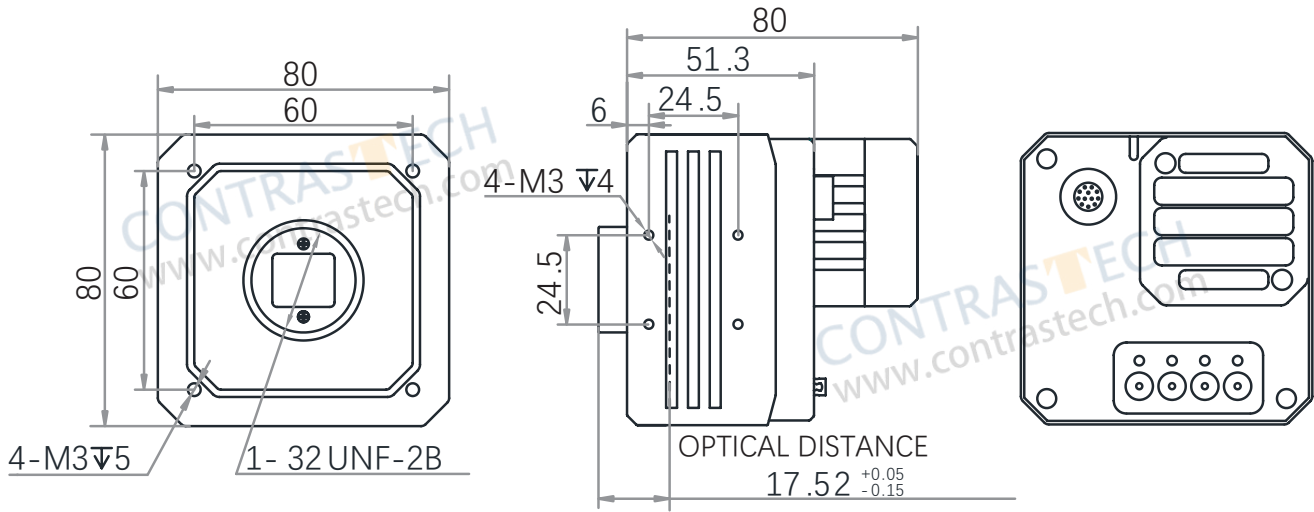

Fig. 1-6: 80 * 80 * 80 mm mechanical dimensions of the CoaXPress camera with C-Mount, which adopts M3 specification screws.

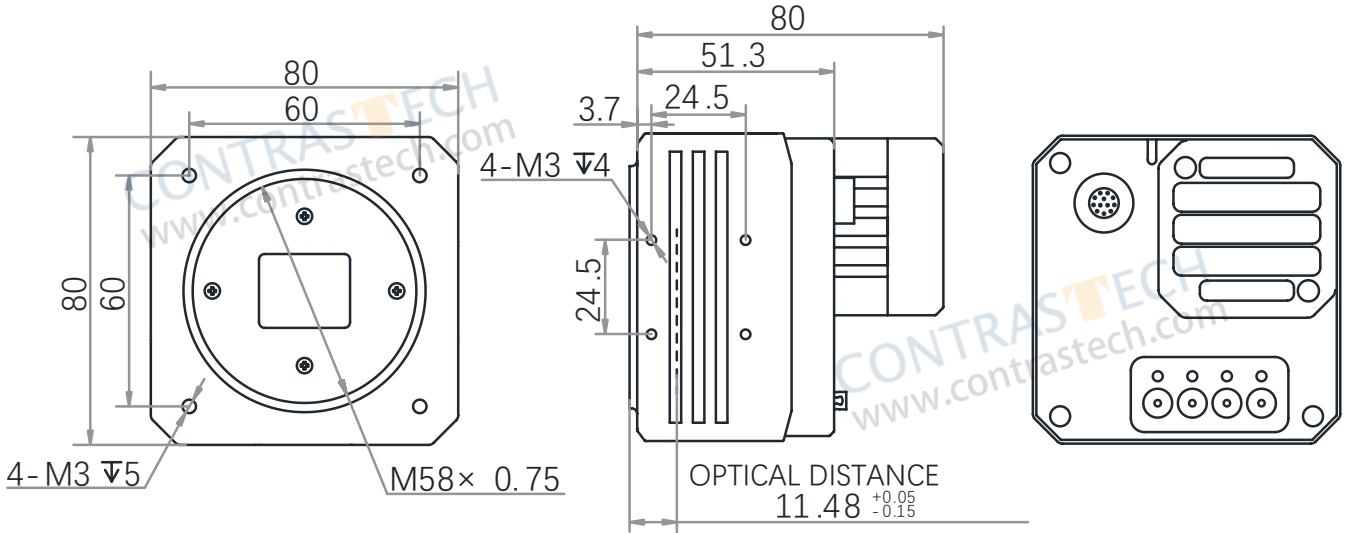

Fig. 1-7: 80 * 80 * 80 mm mechanical dimensions of the CoaXPress camera with M58, which adopts M3 specification screws.

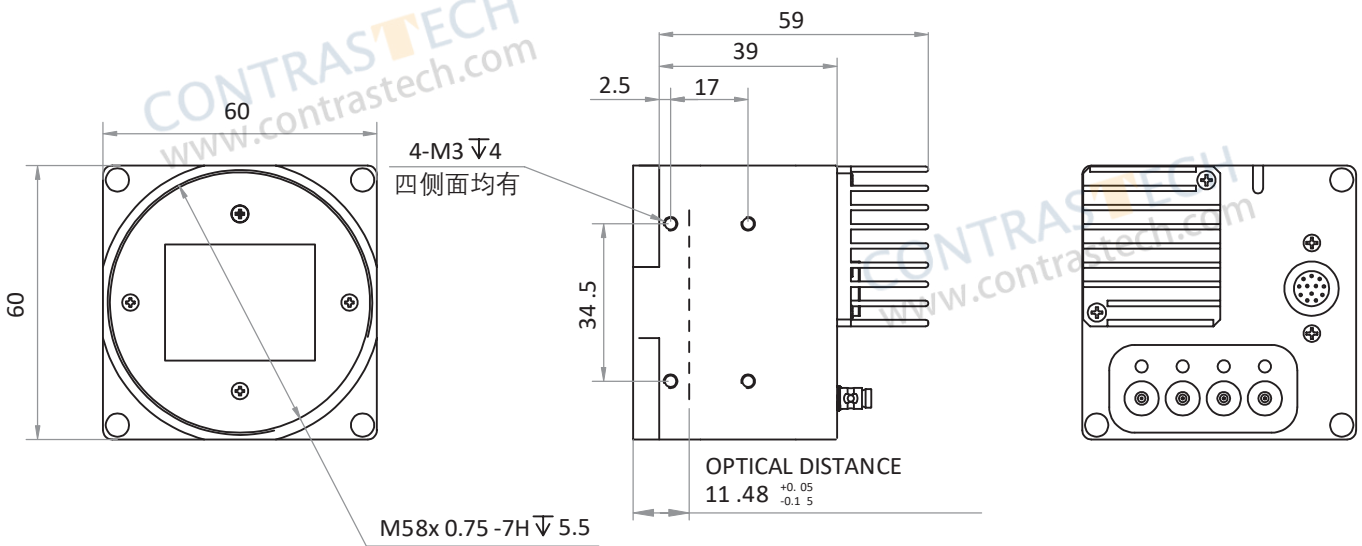

Fig. 1-8: 60 * 60 * 59 mm mechanical dimensions of the CoaXPress camera with M58, which adopts M3 specification screws.

Mechanical Dimensions

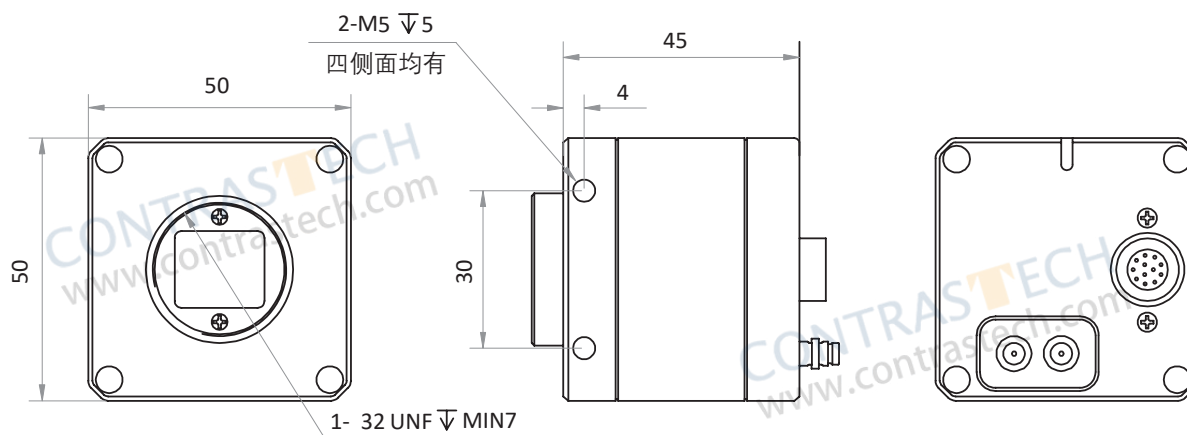

Fig. 1-9: 50 * 50 * 45 mm mechanical dimensions of the CoaXPress camera with C-Mount, which adopts M5 specification screws.

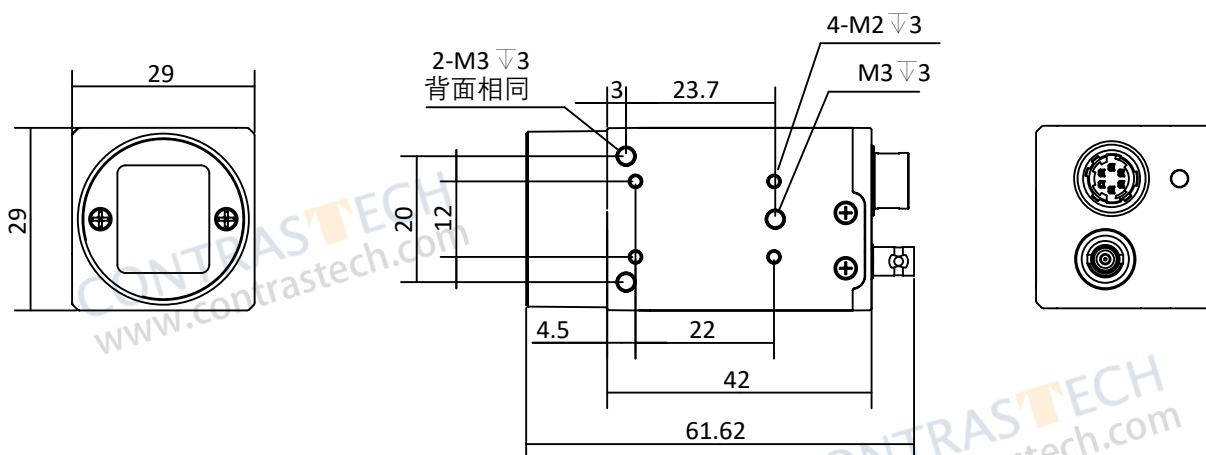

Fig. 1-10: 29 * 29 * 42 mm mechanical dimensions of the CoaXPress camera with C-Mount, which adopts M2/M3 specification screws.

Status LED Description

CXP-6 Camera Status LED	Description
Unlit	The device is powered off.
Solid Green	CoaXPress linking connected without data transmission, or data transmission error occurs (e.g. CRC error).
Fast Flashing Green	The device is acquiring images in continuous mode.
Slow Flashing Green	The device is acquiring images in trigger mode.
CXP-12 Camera Status LED	Description
Unlit	The device is not powered on, or incorrect CoaXPress wiring.
Solid Orange	The device system is starting.
Slow Flashing Red	The device is powered on, but CoaXPress linking is not connected.
Solid Green	The device is connected with the PC, but no data is being transferred.
Fast Flashing Green	The device is acquiring images in continuous mode.
Fast Flashing Orange	The device is connected with the PC, and data is being transferred.
Slow Flashing Orange	The device is acquiring images in trigger mode.



Currently, only some models have CXP link indicator, please refer to the actual equipment.

CHAPTER 2 POWER AND I/O INTERFACE DEFINITION

I/O Connection Definition and Assignments

For different models of CoaXPress Area scan cameras have a 6-pin or 12-pin power and I/O interface, and pin definitions are as follows.

F-Mount and M58(CXP-6 interface) CoaXPress Area Scan Camera

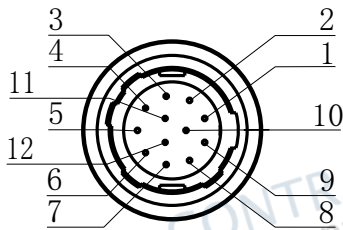

Table 2-1
12-pin I/O Interface Description

Color	Pin	Signal	I/O Signal Source	Description
Black	1	GND	Line 2-	Power supply ground
Red	2	DC_PWR	-	DC Power +
Brown	3	-	-	-
Orange	4	-	-	-
Yellow	5	GND_IO	Line 0/1-	Opto-isolated output signal ground
Green	6	-	-	-
Blue	7	-	-	-
Purple	8	RS232_RX	-	RS232 receives
Gray	9	RS232_TX	-	RS232 transmits
White	10	GPIO2	Line 2+	Input or output
Pink	11	OPTO_OUT0	Line 1+	Opto-isolated output
Light green	12	OPTO_IN0	Line 0+	Opto-isolated input

C-Mount/M58(CXP-12 interface) and M72(CXP-6 interface) CoaXPress Area Scan Camera

Color	Pin	Signal	I/O Signal Source	Description
Black	1	GND	Line 2-	Power supply ground
Red	2	DC_PWR	-	DC Power +
Brown	3	DC_PWR	-	DC Power +
Orange	4	OPTO_IN-	Line 0-	Opto-isolated input signal ground
Yellow	5	OPTO_OUT-	Line 1-	Opto-isolated output signal ground
Green	6	GND	-	Power supply ground
Blue	7	GND	-	Power supply ground
Purple	8	RS232_RX	-	RS232 receives
Gray	9	RS232_TX	-	RS232 transmits
White	10	GPIO2	Line 2+	Input or output
Pink	11	OPTO_OUT+	Line 1+	Opto-isolated output
Light green	12	OPTO_IN+	Line 0+	Opto-isolated input

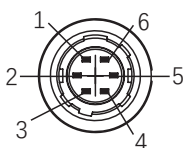

Table 2-2:
Numbering and assignments for
6pin Power and I/O Input Connector:

Color	Pin	Signal	Signal Source	Designation
Red	1	DC_PWR	-	DC Camera Power
Green	2	OPTO_IN	Line 0+	Opto-isolated IN
White	3	GPIO	Line 2+	Can be configured as input or output
Blue	4	OPTO_OUT	Line 1+	Opto-isolated OUT
Brown	5	OPTO_GND	Line 0/1-	Opto-isolated Signal Ground
Black	6	GND	Line 2-	Camera Power Supply Ground

The wire color of this user manual is the color of ConrasTech. If you use other manufacturers' cable color definitions may be different, random connection may cause the camera to burn out, please connect according to the I/O port type and pin definition or contact our technical staff for advise.

CHAPTER 3 INSTALLATION AND SETUP

You should perform the software installation procedure first and the hardware installation procedure second.

Software Installation

■ iDatum Installation

If you use a firewall on your computer, disable the firewall for the network adapter to which your camera is connected.

Close the Firewall

In order to ensure the camera software keep running and image transmission stability, please close the firewall before using the software.

System Requirements

LEO Camera Software Suite for Windows requirements that one of the following operating systems is installed on your computer:

- Windows XP (32 bit)
- Windows 7 (32 bit or 64 bit)
- Windows 10 (32 bit or 64 bit)

Installation Steps

- 1.You can download the iDatum software (LEO Series Industrial Cameras SDK For xxx) from:
<http://www.contrastech.com/en/service/005001.html>
- 2.Double click iDatum installation package to install the client.
- 3.Follow the instructions on the screen. The installer will guide you through the installation process.

■ Frame Grabber Software Installation

The CoaXPress frame grabber client software is used to connect camera, acquire image data, set camera parameters, etc., You can check whether the frame grabber driver is installed correctly through the device manager of the PC. If the installation is correct, the detailed information of the frame grabber driver will be displayed in the device manager. Different manufacturers of frame grabber software display different in the device manager. For the actual use of frame grabber software, please consult the frame grabber manufacturer.

Camera Installation

The installation procedures assume that you will be making a peer-to-peer connection between your camera and a frame grabber.

Make sure that the following items are available before starting the installation:

- LEO CoaXPress Area Scan Camera
- Applicable CoaXPress cables and I/O cables
- It refers to the lens that matches with lens mount of the camera.
- CoaXPress frame grabber
- The computer must be equipped with appropriate operating system

Steps:

- Mount lens that matches with lens mount of the camera
- Connect the camera to CoaXPress frame grabber via CoaXPress cable.
 - The CoaXPress interface on the camera side is DIN or Micro-BNC interface. Please select the correct CoaXPress cable for connection, and make sure that the interface sequence on the camera side corresponds to the interface sequence of the frame grabber.
 - The camera has 4 CoaXPress interfaces, and it can transmit data via 1, 2 or 4 interface(s). The number of interfaces used is different, the data bandwidth that can be transmitted is different, and the camera interface used is also different. For different camera models, the silk screen of the back interface is different, and the camera interface used is also different. It is mainly divided into two interface silk screens: CXP0 ~ CXP3 or CXP1 ~ CXP4. The corresponding relationship is shown in the table below:

Used number	Camera interface
1	CXP1 CXP0
2	CXP1, CXP2 CXP0, CXP1
3	CXP1, CXP2, CXP3, CXP4 CXP0, CXP1, CXP2, CXP3

- CoaXPress-ported industrial cameras have two types of power supply: PoCXP power supply and external DC power supply. When both external DC power supply and PoCXP power supply are present, the external DC power supply takes priority over the camera. If the external DC power supply is unplugged at this time, the camera will switch to PoCXP power supply, which may reboot the camera.

- PoCXP power supply: Power over CoaXPress (PoCXP) is used to supply power, the number of power supply channels supported by different cameras varies, so please refer to the actual equipment.

- DC power supply: Insert the 12-pin connector of the power cord into the 12-pin connector of the camera to supply power to the camera, please refer to the camera label for the specific power supply voltage range used.



To ensure the normal operation and safe use of the camera, please ensure that the output voltage of the DC power supply or adapter is 24V.

Software Operation

1、Double-click the iDatum shortcut on the desktop to open up the client software.

■ Main interface

For specific main window of the client software, please refer to the actual one you got.

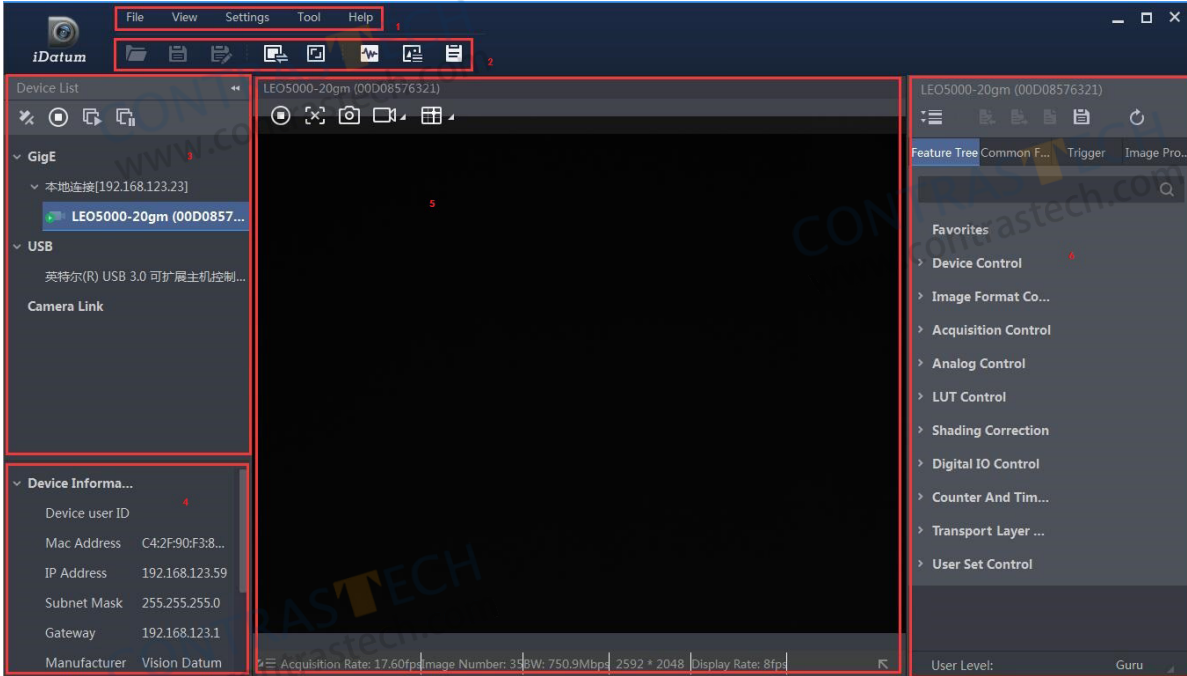

① Menu Bar

The menu bar for iDatum client provides following functions: File, View, Settings, Tool and Help, as shown in the figure below.

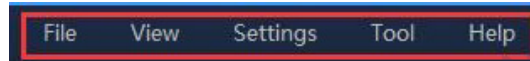

② Control Toolbar

The control toolbar provides quick operations for the device. the icon meaning is shown in the figure below. The operation buttons in the tool bar can quickly and conveniently edit camera images.

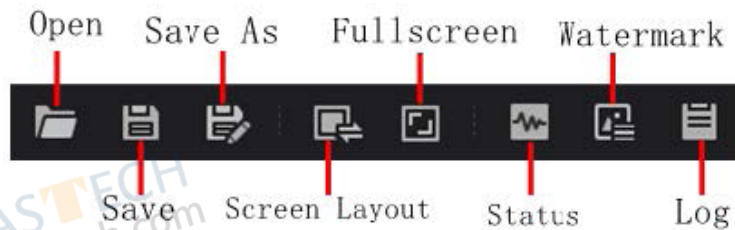

The meaning of shortcut icons in Device List is shown as below.

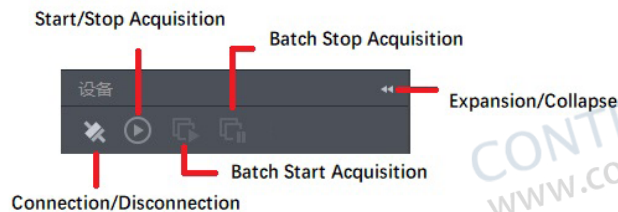

■ Connection/Disconnection: After you selecting the camera, click "Connect" to connect the camera; click "Disconnect" to disconnect the camera.

■ Start/Stop Acquisition: For current connected camera, click "Start Acquisition" to acquire image data; click "Stop Acquisition" to stop image data acquisition.

■ Batch Start Acquisition: click "Batch Start Acquisition" to start image data acquisition for all currently connected camera by iDatum.

■ Batch Stop Acquisition: click "Batch Stop Acquisition" to stop image data acquisition for all currently connected camera by iDatum.

■ Expansion/Collapse: This function can be used to expand or collapse the Device List and Device Information which list on the left side of iDatum, and the default state is expansion. In the "Collapse" state, the iDatum left side only display the searched cameras.

Software Operation

- 2、Click in device list  to search the device.
- 3、Select a device to be connected.
- 4、Click ">" in the camera's feature panel to unfold the specific camera parameters, and set them according to actual demands. Please see the table below for the introduction of each attribute classification.

Attribute	Description
<i>Device Control</i>	You can view the device information, edit its name, reset the device, etc.
<i>Image Format Control</i>	You can view and set the device's resolution, image reverse function, pixel format, region of interest, test pattern, etc.
<i>Acquisition Control</i>	You can view and set the device's acquisition mode, frame rate, trigger mode, exposure time, etc.
<i>Analog Control</i>	You can view and set the camera's analog signal, including gain, black level, Gamma correction, sharpness, etc.
<i>LUT Control</i>	You can view the Look-Up Table (LUT), and set its index and value.
<i>Shading Correction</i>	You can set shading correction to correct shade.
<i>Counter And Timer Control</i>	You can view and set the counter related parameters.
<i>Digital IO Control</i>	You can set the different input and output signals.
<i>Transport Layer Control</i>	You can view and set the parameters of the device's transport layer.
<i>User Set Control</i>	You can save or load the camera's parameters. You can set the default parameter when running the frame grabber software.
<i>CoaXPress</i>	You can set CoaXPress related parameters.

- 5、Set the Link configuration mode through the LinkConfiguration parameter under CoaXPress properties, and you can set the number of links and the transmission bandwidth of each link.

	The camera's attribute tree and parameters may differ by camera models.
--	---

CHAPTER 4 CAMERA FEATURES

Global Shutter and Rolling Shutter

Global Shutter

For camera that supports global shutter, its exposure starts and ends in each line simultaneously. After the exposure, data readout starts line by line. All pixels expose at the same time, then readout at different time, as shown below.

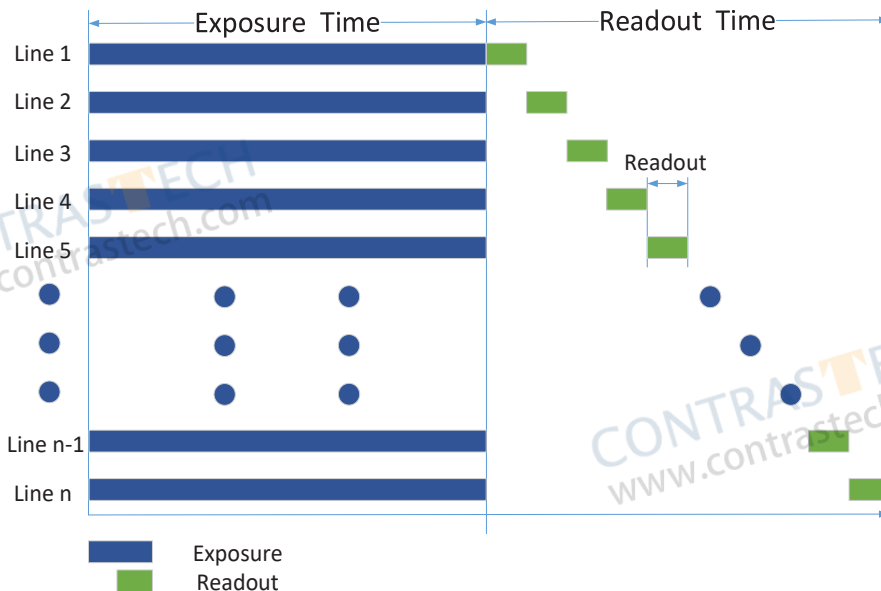

Rolling Shutter

For cameras that support rolling shutter: as soon as the exposure ends, and the data readout starts simultaneously. After the whole action, the rest of rows start to expose and read out one by one. All pixels expose at the same time, then readout at different time, as shown below.

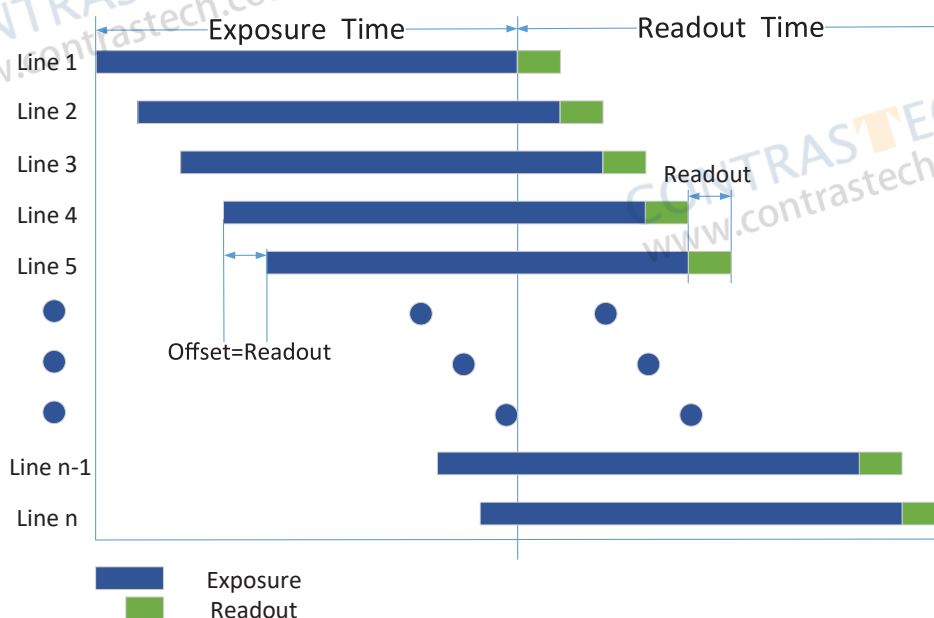

Global Shutter and Rolling Shutter

Global Reset

Only some models of cameras with rolling shutter support the Global Reset function. Global reset means that all of the sensor's pixels start exposing at the same time, but stop exposing at different time.

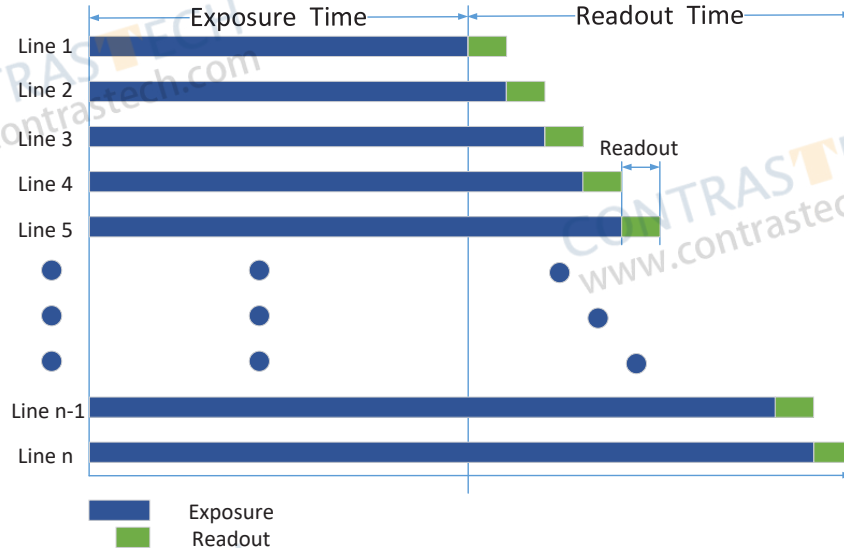

When you need to use the Global Reset function, You can go to Acquisition Control > Sensor Shutter Mode, and select Sensor Shutter Mode to Global Reset.



- For different models of camera, the global reset function may differ,
- Only when the Trigger Mode is On, you can set Sensor Shutter Mode.
- After the Global Reset function is turned on, due to the different exposure time of each line of the image, the brightness of each line of the image may be different from top to bottom. Therefore, if this function is turned on, it is recommended to use it with a light source in a dark environment. Turn on the light source during the exposure time shown in the figure above, and turn off the light source at other times, so that each line of the image gets the same illumination during the same exposure time, so as to control the brightness of each line of the image.

Overlap Exposure And Non-Overlap Exposure

The process that camera captures one frame of image includes two stages, exposure and readout. According to the overlap relation between the exposure time and the readout time, cameras with different sensors can be divided into overlap exposure and nonoverlap exposure. Compared with non-overlap exposure, overlap exposure can reduce the influence of exposure time on grabbing time.

The products mentioned in this manual use overlap exposure to process image data.

This can be set using the **Overlap Mode** parameter under the **Acquisition Control** property. If **Overlap Mode** is selected on, it is an overlap exposure mode; if **Overlap Mode** is selected off, it is a non-overlap exposure mode.

■ Non-Overlap Exposure

After completing the current frame's exposure and readout, the next frame starts to expose and read out. This process is called non-overlap exposure. The non-overlap exposure's frame period is larger than the sum of the exposure time and the readout time, as shown below.

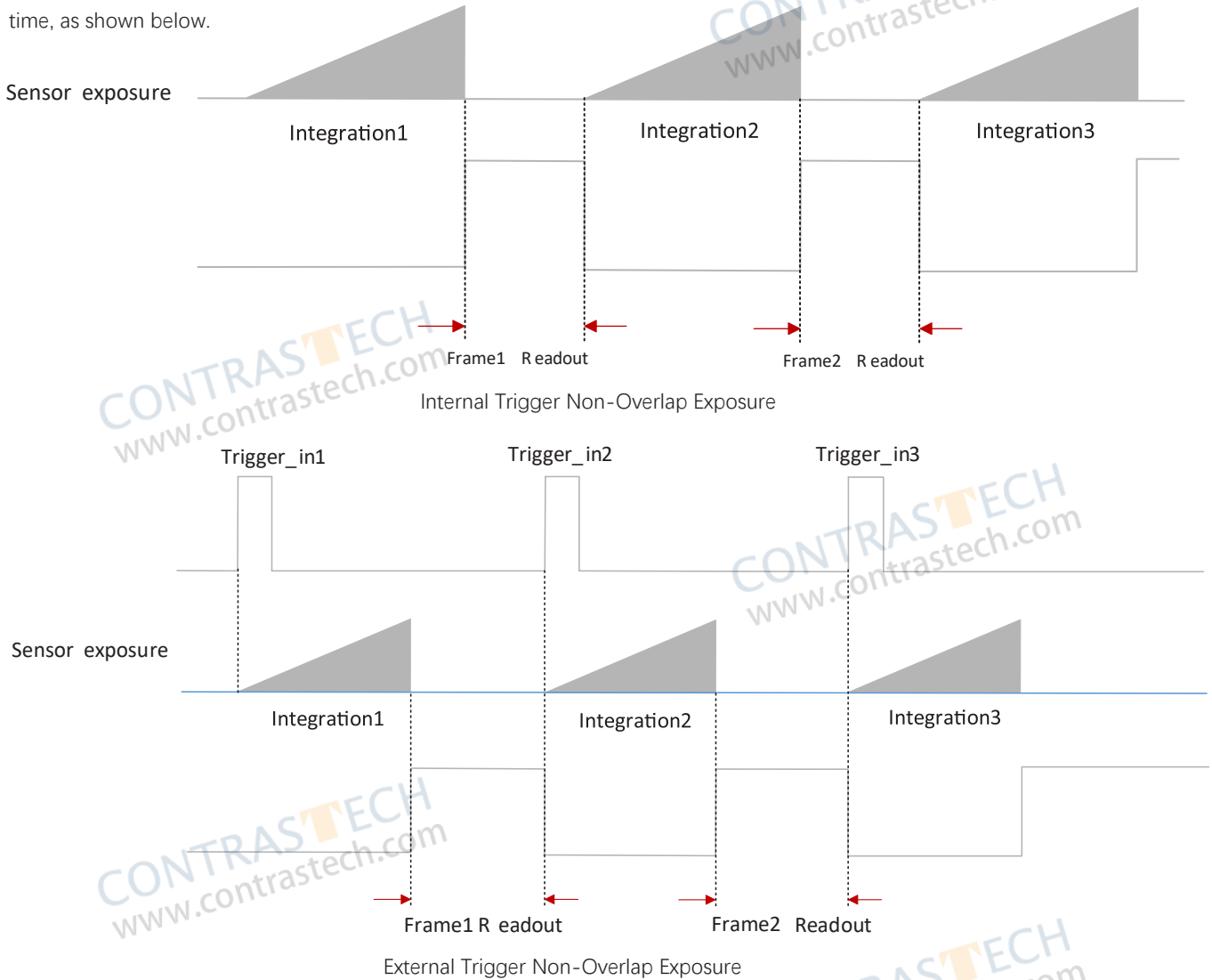

The camera will ignore the external signal in the readout section under this mode.

Overlap Exposure And Non-Overlap Exposure

■ Overlap Exposure

Overlap exposure refers to the overlap between the current frame exposure and the previous frame readout. In other words, when the previous frame starts to read out, the current frame starts to expose simultaneously, as shown below.

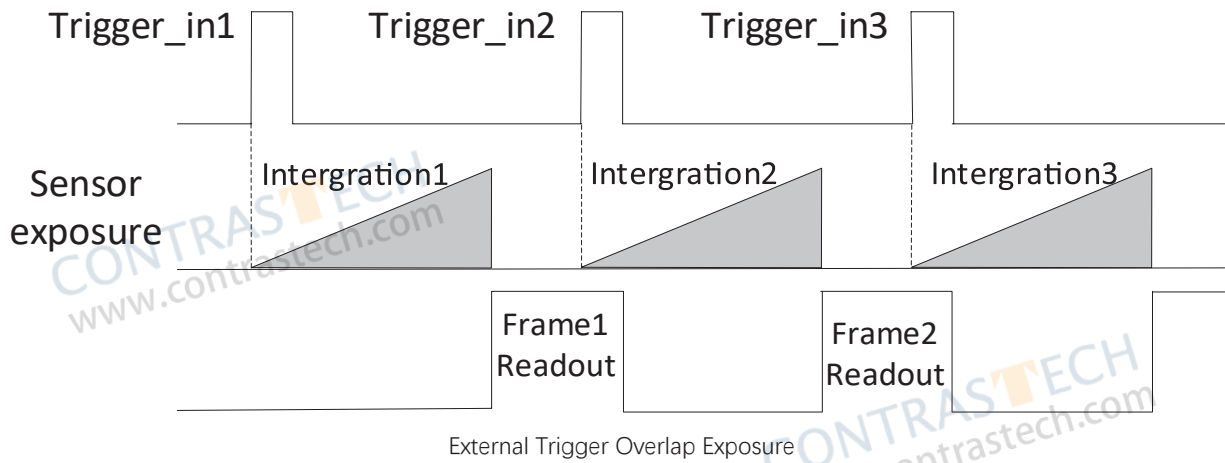
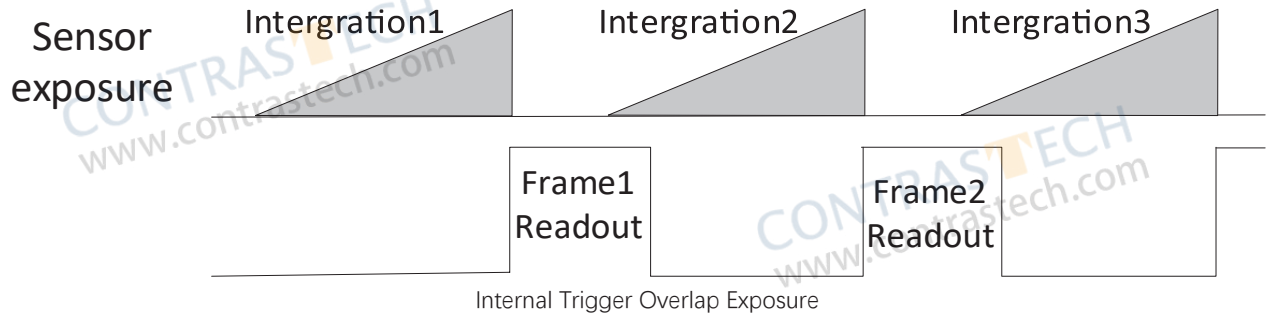

CHAPTER 5

IMAGE ACQUISITION

Frame Rate

Frame rate refers to the image number that is acquired by the camera per second. The higher frame rate, and shorter time used for image acquisition will be.

The following 4 factors determines the camera's frame rate in real-time.

- **Frame readout time:** The frame readout time is related with camera's sensor performance and image height. The lower the image height and less the frame readout time, and the higher the frame rate will be.
- **Exposure time:** If the reciprocal of max frame rate that the camera supports is t , and when the configured exposure time is larger than t , the less the exposure time, the higher the frame rate will be. When the configured exposure time is less than or equal to t , exposure time will not influence the frame rate.
- **Bandwidth:** The larger the bandwidth, the higher the frame rate will be.
- **Pixel format:** The more bytes pixel format occupy, the lower the frame rate will be.

The camera can also manually control the real-time frame rate.

The specific steps are as follows:

1. Click Acquisition Control > Acquisition Frame Rate, enter Acquisition Frame Rate according to actual demands, and enable Acquisition Frame Rate Control Enable.

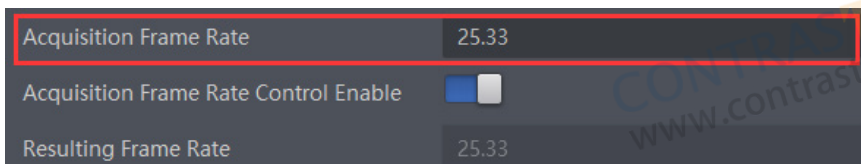

_If the current real-time frame rate is smaller than configured frame rate, the camera acquires images according to the real-time frame rate.

_If the current real-time frame rate is larger than configured frame rate, the camera acquires images according to the configured frame rate.

2. You can refer to Resulting Frame Rate to view the camera's resulting frame rate.

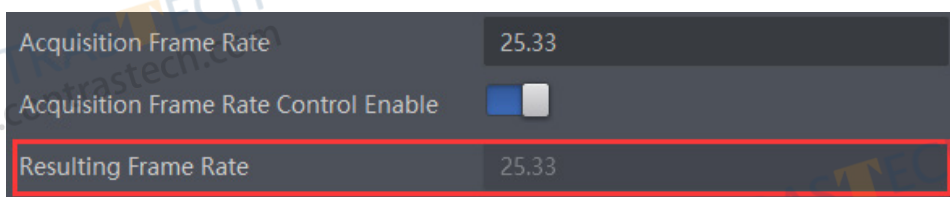

Device Tap Geometry

The camera supports switching Tap mode, which can be set via the Device Tap Geometry parameter under the Transport Layer Control property.

The camera's tap mode must correspond to the frame grabber's configuration mode, otherwise the camera image will be abnormal. Different tap modes will result in different image outputs. Currently, the camera only supports Geometry_1X_1Y and Geometry_1X_2YE tap modes.

- When Geometry_1X_1Y is used, the output image is as follows.

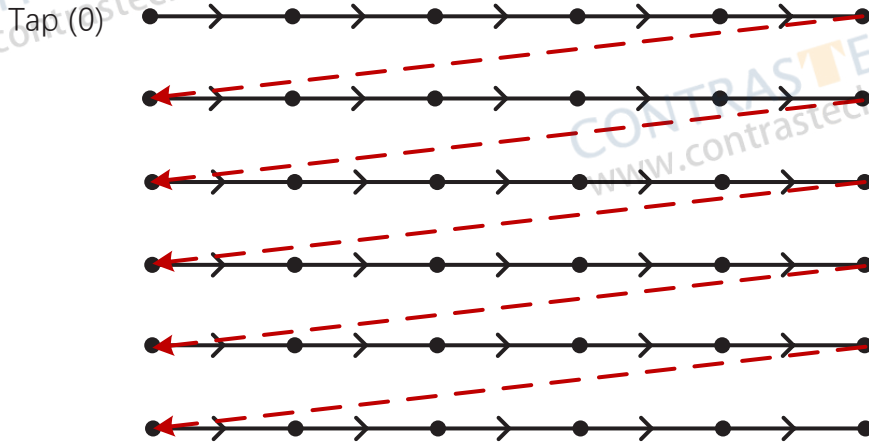

- When Geometry_1X_2YE is used, the output image is as follows.

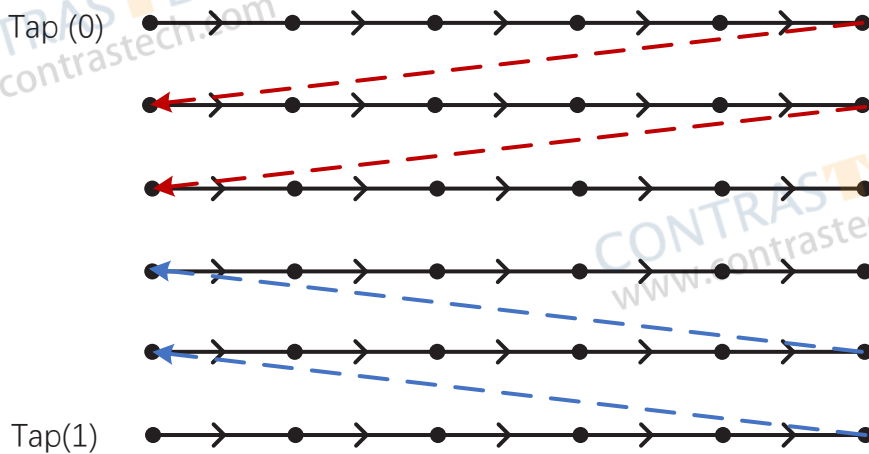

Trigger Mode

The camera has 2 types of trigger mode, including internal trigger mode and external trigger mode.

Internal trigger mode(acquisition modes), including SingleFrame mode and Continuous mode;external trigger mode, including software trigger, hardware trigger.

Trigger Mode	Parameter	Parameter Value	Principle
Internal trigger mode	Acquisition Control > Trigger Mode	Off	The camera acquires images via its internal signals.
External trigger mode		On	The camera acquires images via external signals. These signals can be software signal and hardware signal, including software trigger, hardware trigger, counter trigger and link trigger.

Internal trigger mode

Their principle and parameter setting are shown below.

Internal trigger mode	Parameter	Parameter Value	Principle
SingleFrame mode	Acquisition Control > Acquisition Mode	SingleFrame	When camera starts image acquisition, it acquires one image only, and then stops.
Continuous mode		Continuous	When camera starts image acquisition, it acquires images continuously. Real-time frame rate decides the acquisition frame number per second. You can stop camera image acquisition manually.

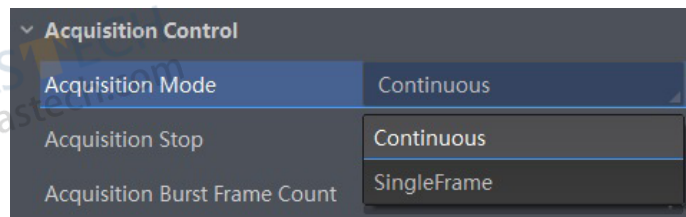

External trigger mode

The external trigger signals types of trigger camera acquisition can be given by software or external device.

External Trigger Source

There are 5 types of external trigger sources, including software trigger, hardware trigger, counter trigger, link trigger, and free trigger.

Their principle and parameter setting are shown below.

External trigger mode	Parameter	Parameter Value	Principle
Software Trigger	Acquisition Control > Trigger Source	Software	The software sends trigger signal to the camera via CoaXPress interface to acquire images.
Hardware Trigger		Line 0 / Line 2	External device connects camera via camera I/O interface. External device sends trigger signal to camera to acquire images.
Counter Trigger		Counter 0	The counter sends trigger signal to the camera to acquire images.
Link Trigger		Link Trigger 0	The frame grabber sends trigger signal to the camera to acquire images.
Free Trigger		Anyway	Use software trigger, hardware trigger or counter trigger to send signals to the camera to acquire images.



These 5 external trigger sources are valid only when the Trigger Mode is On.

Software Trigger

For the camera support software trigger mode, when user set software trigger, the client software can send commands to camera to acquires and transfer images via CoaXPress .

- 1.Click Acquisition Control > Trigger Mode, and select On as Trigger Mode.
- 2.Select Software as Trigger Source, and click Execute in Trigger Software to send trigger commands.

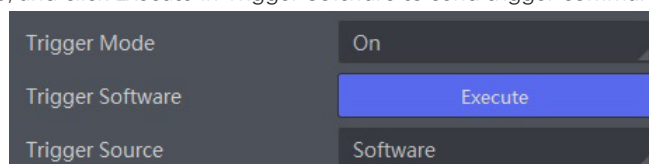

Trigger Mode

■ Hardware Trigger

If set "Hardware" as "Trigger Source" can switched to hardware external trigger mode.

The camera has one opto-isolated input (Line 0), and one bi-directional I/O (Line 2) that can be configured as input signal.



Here we take Line 2 as an example to introduce the hardware trigger settings. You select Line 0 or Line 2 as trigger source to set hardware trigger according to actual demands.

The setting as input signal is as shown below:

1. Click Digital IO Control.
2. Select Line 2 as Line Selector, and Input as Line Mode to set line 2 as input signal.
3. Click Acquisition Control, select On as Trigger Mode, select Line 0 or Line 2 as Trigger Source.

The command to trigger the photo is given to the camera by the external device.

■ Counter Trigger

The counter trigger provides frequency division to the external trigger signal. The camera performs an external trigger after receiving multiple hardware trigger signals.

1. Click Acquisition Control > Trigger Mode, and select On as Trigger Mode.
2. Select Counter 0 as Trigger Source.

When using counter as trigger source, you need to set relevant parameters under Counter And Timer Control. For specific parameter function and setting, please refer to the following table.

Parameter	Read/Write	Description
Counter Selector	Read and write	It selects counter source. Counter 0 is available only at present.
Counter Event Source	Read and write	It selects the signal source of counter trigger. Line 0, Line 2 or Link Trigger 0 is available. This parameter is disabled by default.
Counter Reset Source	Read and write	It selects the signal source of resetting counter. Software is available only. It is disabled by default.
Counter Reset	Write is available under certain condition	It resets counter and it can be executed when selecting Software as Counter Reset Source.
Counter Value	Read and write	It is the counter value with the range of 1 to 1023. For example, if the parameter is set to n, then the trigger signal n times can execute the counter trigger once to obtain 1 frame of image.
Counter Current Value	Read only	It displays the number of executed external trigger.

■ Link Trigger

The camera supports trigger via CoaXPress frame grabber, and you can set related parameters as follows.

Steps:

1. Click Acquisition Control > Trigger Selector.
2. Select On as Trigger Mode.
3. Select Link Trigger 0 as Trigger Source.

■ Free Trigger

In the free trigger mode, the camera can receive signals from software trigger, hardware trigger, counter trigger, and link trigger.

Steps:

1. Click Acquisition Control > Trigger Selector.
2. Select On as Trigger Mode.
3. Select Anyway as Trigger Source.



Free trigger function may differ by camera models.

Trigger Mode

■ Trigger Related Parameters

Under external trigger mode, you can set burst frame count, trigger delay, trigger cache enable, trigger activation and trigger debouncer. Different trigger sources can set various trigger parameters, and their relation is shown below.

Trigger Source Trigger Parameter	Software Trigger	Hardware Trigger	Counter Trigger	Link Trigger	Free Trigger
Burst Frame Count	√	√	√	√	√
Trigger Delay	√	√	√	√	√
Trigger Cache Enable	√	√	√	√	√
Trigger Activation	×	√	√	√	√
Trigger Debouncer	×	√	×	×	×

Burst Frame Count

Under external trigger mode, you can set burst frame count as shown below.

Click Acquisition Control > Acquisition Burst Frame Count, and enter Acquisition Burst Frame Count according to actual demands. Its range is from 1 to 1023.



When Acquisition Burst Frame Count is 1, it is in single frame trigger mode. When Acquisition Burst Frame Count is larger than 1, it is in multi-frame trigger mode. If Acquisition Burst Frame Count is n and when inputting 1 trigger signal, the camera stops acquiring images after exposing n times and outputs n frame images. The sequence diagram of burst frame count is shown below.

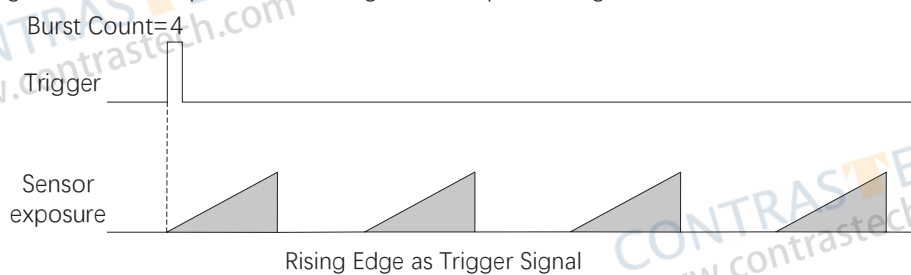

Trigger Delay

From camera receiving signal and responding, this period is trigger delay. Its sequence diagram is shown below.

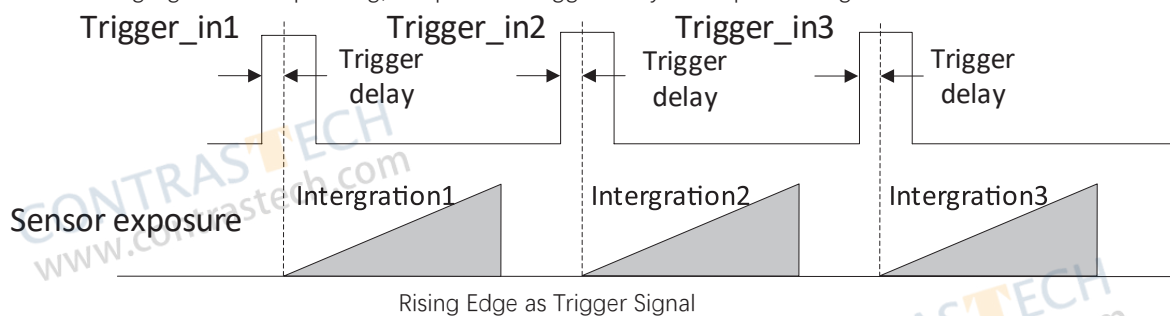

You can enter Trigger Delay according to actual demands, and its range is from 0 μ s to 16000000 μ s.

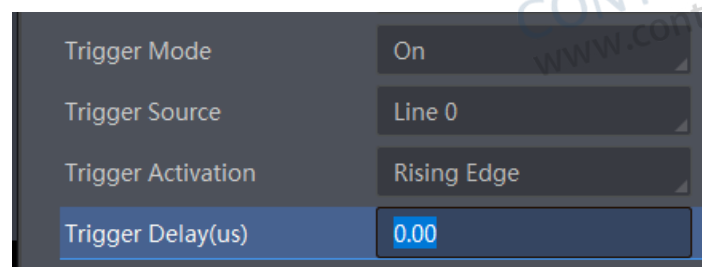

Trigger Mode

Trigger Cache Enable

The camera has the function of Trigger Cache Enable. During the triggering process, if the camera receives new trigger signal, it will save and process the signal if you enable this function. Trigger cache enable can save up to 3 trigger signals.

Click Acquisition Control > Trigger Cache Enable, and enable Trigger Cache Enable.

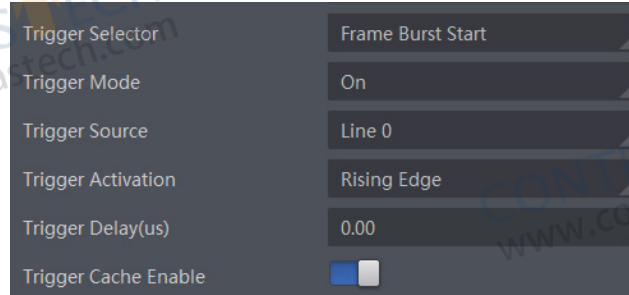

For example, if the device receives the 2nd trigger signal when it is processing the 1st trigger signal, and the result will be different depending on whether Trigger Cache Enable is enabled or not.

- The 2nd trigger signal will be filtered without processing if Trigger Cache Enable is disabled.

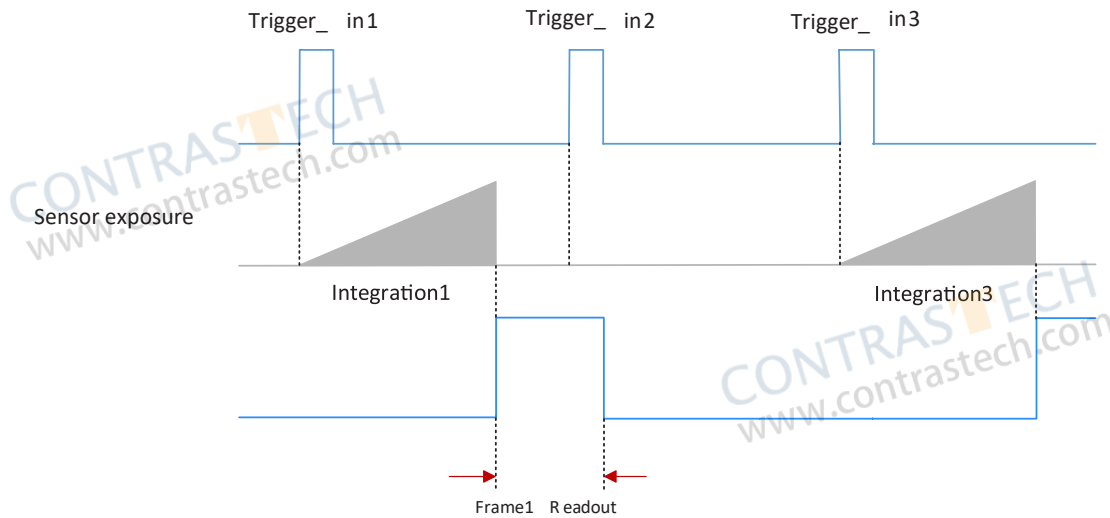

- The 2nd trigger signal will be saved if Trigger Cache Enable is enabled.

If the 1st frame image's exposure time of the 2nd trigger signal is not earlier than the device's last frame creation time of the 1st trigger signal, and then the 2nd trigger signal's 1st frame image is created normally.

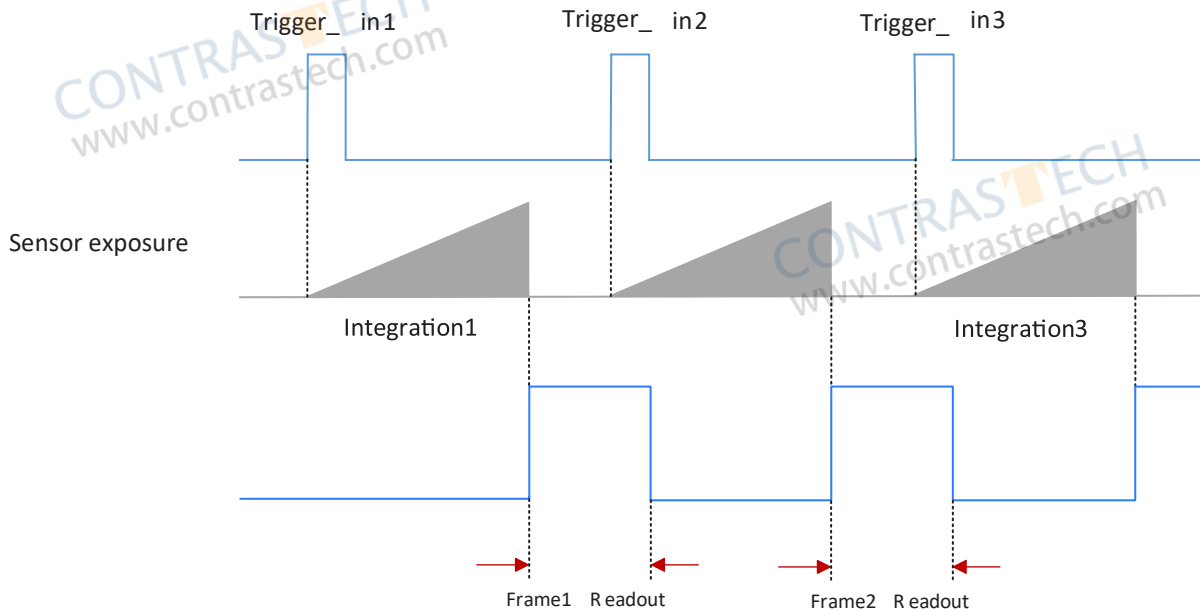

Trigger Mode

If the 1st frame image's exposure time of the 2nd trigger signal is earlier than the device's last frame creation time of the 1st trigger signal, and then the device will delay this exposure time. Thus making sure this exposure time is not earlier than the device's last frame creation time of the 1st trigger signal.

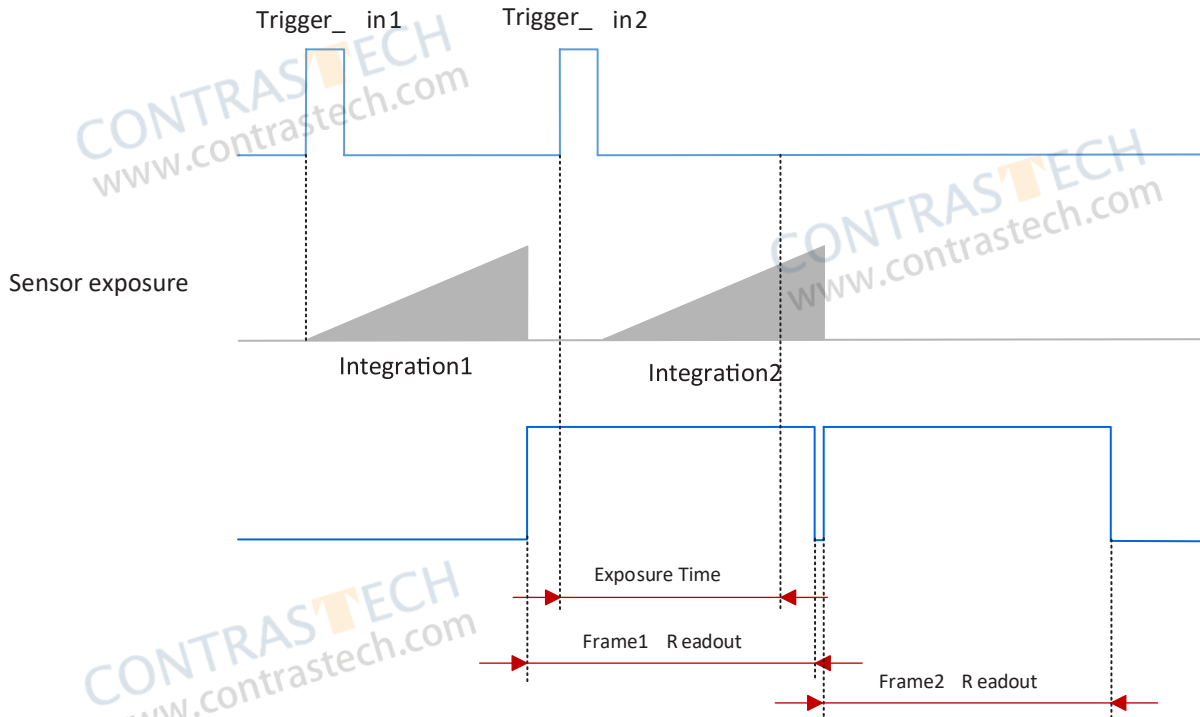

The three sequence diagrams above use rising edge as trigger activation.

Trigger Activation

The camera supports trigger acquisition in the rising edge, falling edge, level high, or level low of the external signal. The principle and parameter of trigger activation are as follows.

Trigger Activation	Parameter	Parameter Value	Principle
Rising Edge	Acquisition Control > Trigger Activation	Rising Edge	Rising Edge refers to the rising edge of the trigger signal is valid, that is camera exposure and acquisition at the beginning of the rising edge of the trigger signal.
Falling Edge		Falling Edge	Falling Edge refers to the falling edge of the trigger signal is valid, that is camera exposure and acquisition at the beginning of the falling edge of the trigger signal.
Level High		Level High	Level High refers to the level high of the trigger signal is valid. As long as trigger signal is in level high, the camera keeps exposure and acquisition status.
Level Low		Level Low	Level Low refers to the level low of the trigger signal is valid. As long as trigger signal is in level low, the camera keeps exposure and acquisition status.

Click Acquisition Control > Trigger Selector > Trigger Activation, and select Rising Edge, Falling Edge, Level High or Level Low as Trigger Activation according to actual demands.

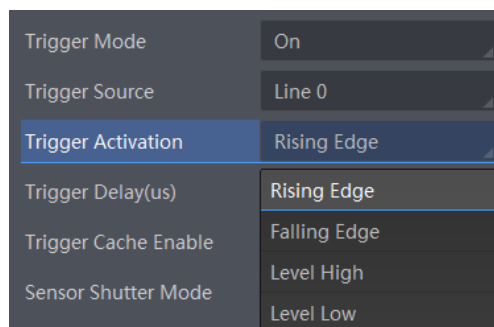

Trigger Mode

Trigger Debouncer

The external trigger input signal of the camera may have signal bounce that may cause false trigger. Thus, it is necessary to debounce the external trigger signal, and its sequence diagram is shown below.

Click Digital IO Control > Line Debouncer Time, and enter Line Debouncer Time according to actual demands. and its range is from 1 μ s to 1000000 μ s.

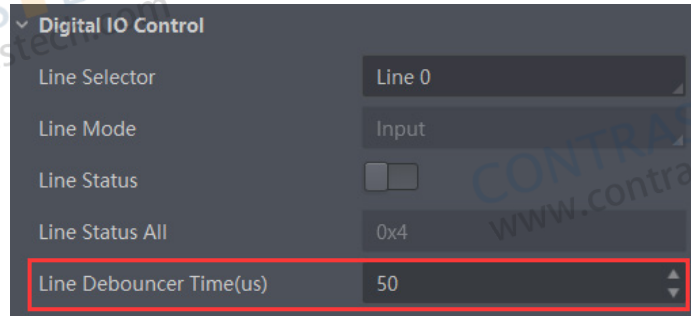

When the set Debouncer time is greater than the trigger signal time, the trigger signal is ignored.

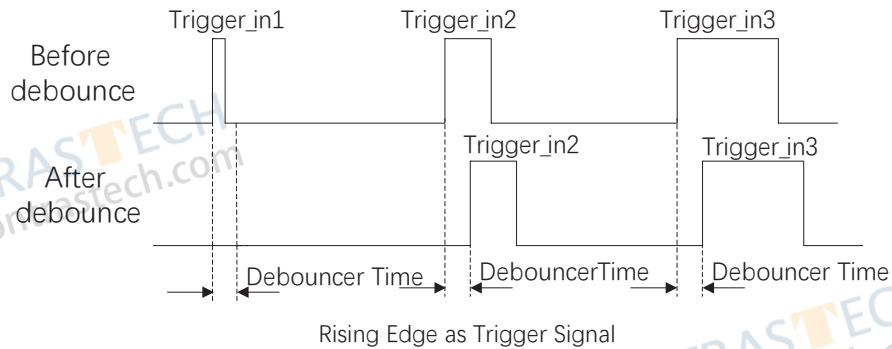

CHAPTER 6 I/O OUTPUT

Select Output Signal

The camera has one opto-isolated output (Line 1), and one bi-directional I/O (Line 2) that can be configured as output signal. Set the output signal as follows:

Click Digital IO Control, select Line 2 as Line Selector, and select Strobe as Line Mode to set line 2 as output signal.

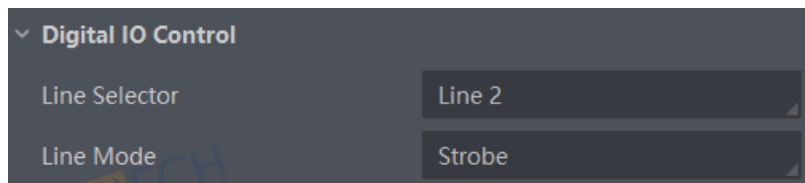

- Here we take Line 2 as an example to introduce how to select output signal. You select Line 1 or Line 2 as line selector according to actual demands.
- For details about the electrical characteristics and wiring of the IO interface, please refer to I/O Electrical Characteristics and Wiring.

Set Output Signal

The output signal of the camera is switch signal that can be used to control external devices such as light source, PLC, etc.

■ Enable Level Inverter

The line inverter function allows the camera to invert the electrical signal level of an I/O line, and meets requirements of different devices for high or low electrical signal level. All high signals are converted to low signals and vice versa.

Click Digital IO Control > Line Selector, select line for Line Selector, and enable Line Inverter. The Line Inverter parameter is disabled by default.

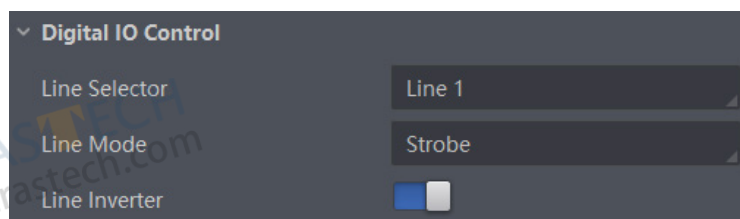

■ Enable Strobe Signal

The strobe signal is used to directly output I/O signal to external devices when camera's event source occurs.

Click Digital IO Control, select different output events as Line Source, and enable Strobe Enable.

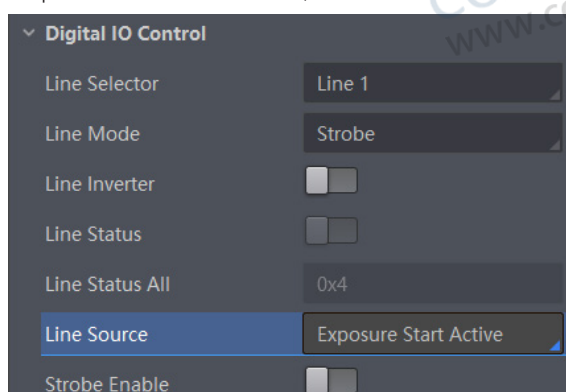

Set Output Signal



For specific Line Source, please refer to following table for details.

Name	Description
Exposure Start Active	It refers to output one I/O edge signal when starting exposure.
Exposure End Active	The device outputs signals to external devices when it stops exposure.
Acquisition Start Active	It refers to output one I/O edge signal when starting acquisition.
Acquisition Stop Active	It refers to output one I/O edge signal when stopping acquisition.
Frame Burst Start Active	It refers to output one I/O edge signal when starting triggering and acquiring images under Burst mode.
Frame Burst End Active	It refers to output one I/O edge signal when stopping triggering and acquiring images under Burst mode.
Frame Start Active	The device outputs signals to external devices when it starts doing the capture of a frame.
Frame End Active	The device outputs signals to external devices when it stops doing the capture of a frame.
Soft Trigger Active	It refers to output one I/O edge signal when software trigger acquisition.
Hard Trigger Active	It refers to output one I/O edge signal when hardware trigger acquisition.
Counter Active	It refers to output one I/O edge signal when counter output is enabled.
Timer Active	It refers to output one I/O edge signal when timer output is enabled.

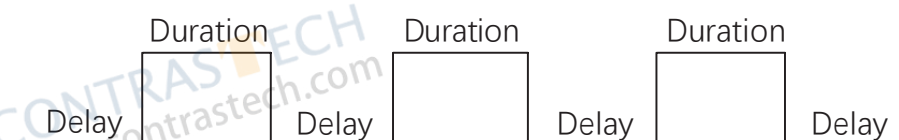
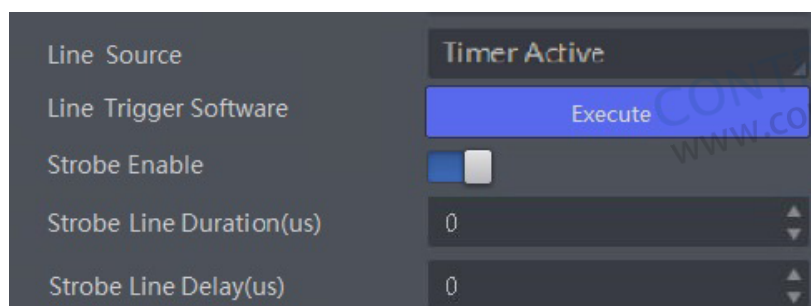
If Timer Active is selected as Line Source, you can set Strobe Line Duration and Strobe Line Delay, and the camera will output signal correspondingly after click Execute in Line Trigger Software.



Regarding strobe signal, you can also set its duration, delay and pre delay.

-  The specific line source may differ by camera models.
-  When the Strobe Line Duration value is 0, the strobe duration is equal to the exposure time. When the Strobe Line Duration value is not 0, the strobe duration is equal to Strobe Line Duration value.

Set Output Signal

Strobe Line Duration

Strobe signal is active Level High, After enabling strobe signal, you can set its duration. Click Digital IO Control > Strobe Line Duration, and enter Strobe Line Duration according to actual demands.

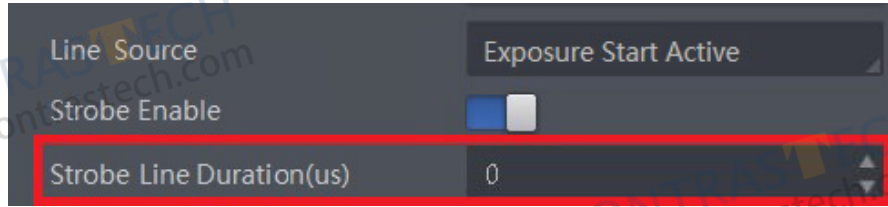

For example, select Line Source as Exposure Start Active. When the camera starts to expose, Strobe outputs immediately. When the Strobe Line Duration value is 0, the strobe duration is equal to the exposure time. When the Strobe Line Duration value is not 0, the strobe duration is equal to Strobe Line Duration value.

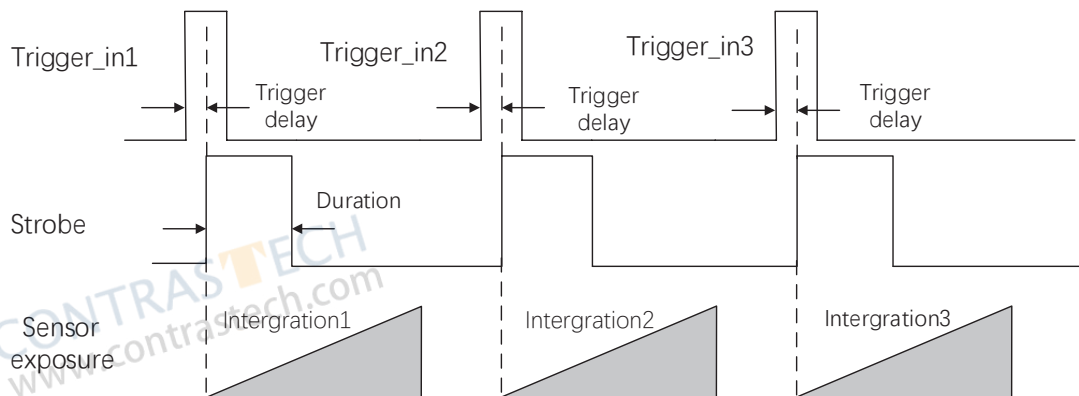

Strobe Line Delay

The camera supports setting strobe line delay to meet actual demands. When exposure starts, the strobe output doesn't take effect immediately. Instead, the strobe output will delay according to the strobe line delay setting.

Click Digital IO Control > Strobe Line Delay, and enter Strobe Line Delay according to actual demands.

The unit is μs and the range is 0~10000, that is, 0~10 ms.

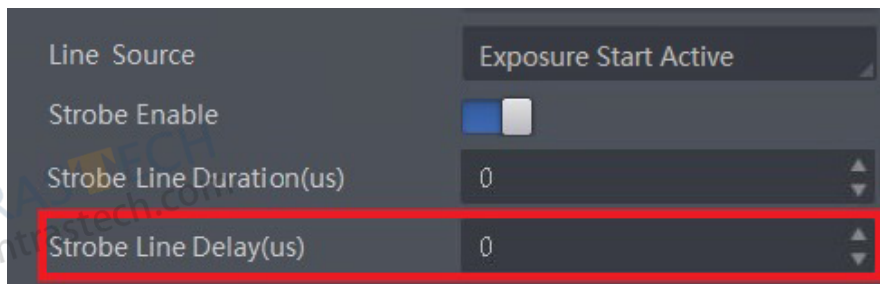

For example, select Line Source as Exposure Start Active.

When the camera starts to expose, the Strobe output does not take effect immediately, but delays the output according to the value set by Strobe Line Delay. The sequence diagram of strobe line delay is shown below.

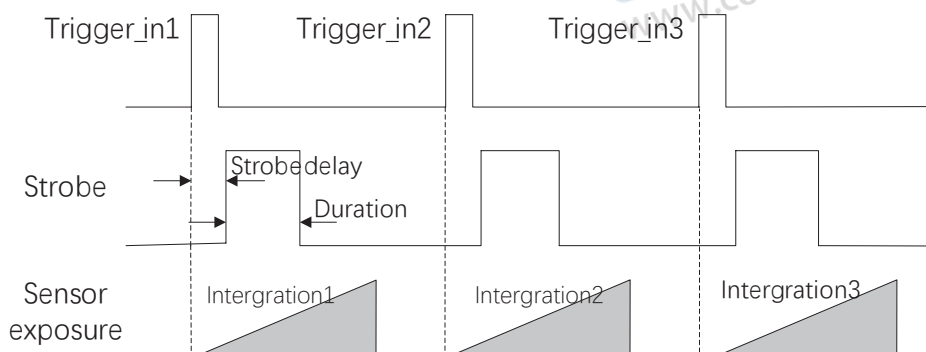

Set Output Signal

Strobe Line Pre Delay

The camera also supports the function of strobe line pre delay, which means that the strobe signal takes effect early than exposure. This function is applied to the external devices that have slow response speed.

Click Digital IO Control > Strobe Line Pre Delay, and enter Strobe Line Pre Delay according to actual demands. The unit is μs and the range is 0~5000, that is, 0~5 ms.

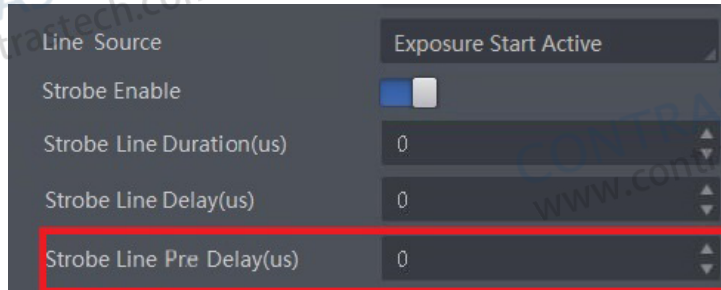

For example, select Line Source as Exposure Start Active.

The camera will delay the exposure according to the value set by Strobe Line Pre Delay. The sequence diagram of strobe line pre delay is shown below.

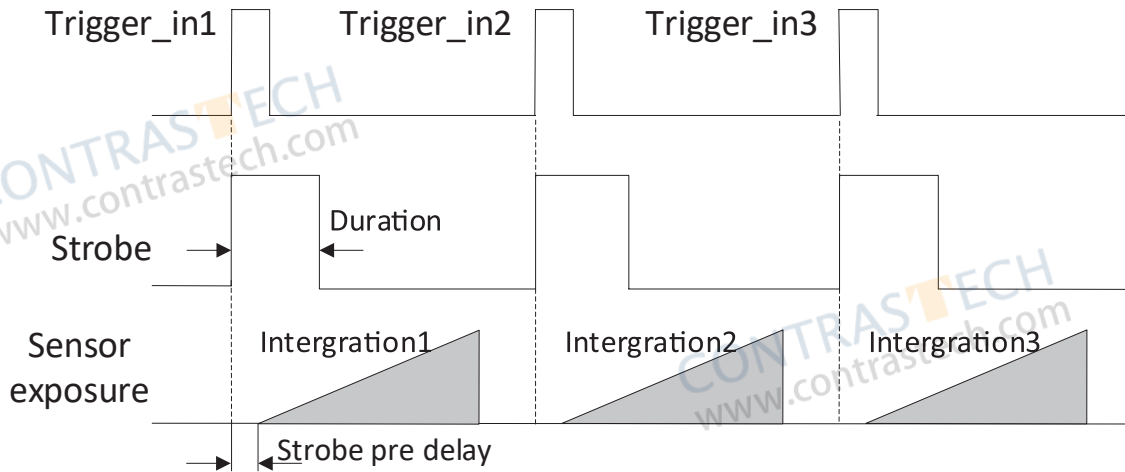

CHAPTER 7

I/O ELECTRICAL FEATURE AND WIRING

I/O Electrical Feature

Line 0 Opto-isolated Input Circuit

The Line 0 opto-isolated input circuit in camera I/O control is shown below.

The maximum input current of Line 0 is 25 mA.

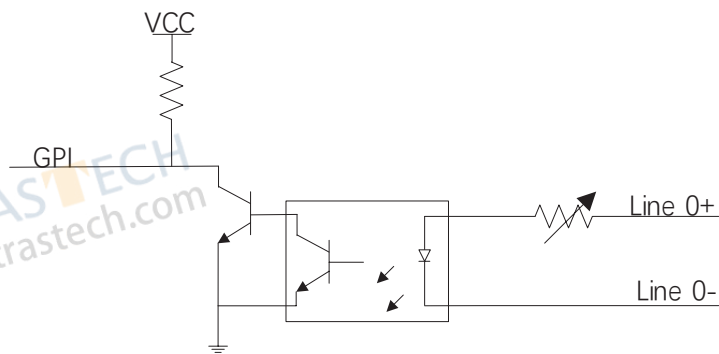

Input Logic Level:

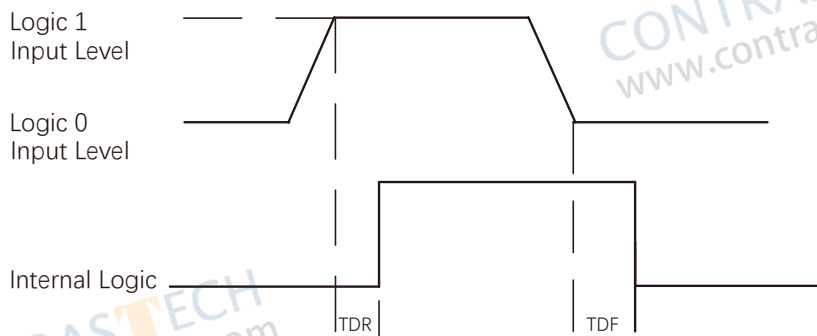

Input Electrical Feature:

Parameter Name	PARAMETER SYMBOL	VALUE
Input Logic Level Low	VL	0 ~ 1 VDC
Input Logic Level High	VH	3.3 ~ 24 VDC
Input Rising Delay	TDR	1.8 ~ 4.6 μ s
Input Falling Delay	TDF	16.8 ~ 22 μ s



- Make sure the input voltage is not from 1 VDC to 3.3 VDC as the electric status between these two values are not stable.
- The breakdown voltage is 30 VDC, and keep voltage stable.

I/O Electrical Feature

Line 1 Opto-isolated Output Circuit

The Line 1 opto-isolated output circuit in camera I/O control is shown below.

The maximum output current of Line 1 is 25 mA.

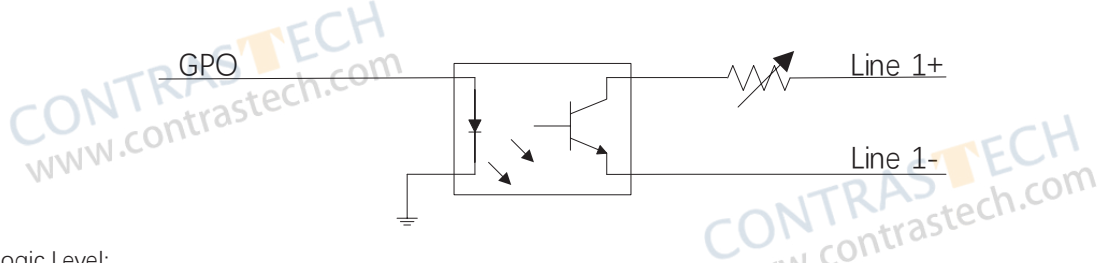

Output Logic Level:

The maximum output current of Line 1 is 25 mA and output impedance is 40 Ω .

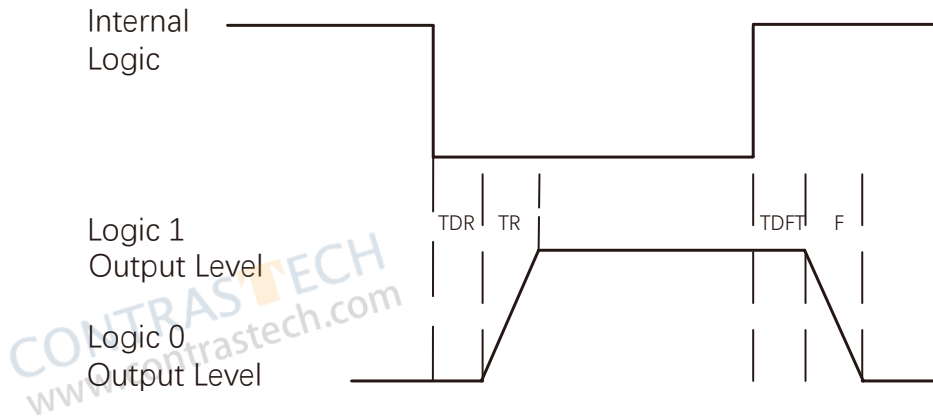

Opto-isolated output electric feature is shown in below (when the external voltage is 3.3 VDC and the external resistance is 1 K Ω).

Parameter Name	Parameter Symbol	Value
Output Logic Level Low	VL	575 mV
Output Logic Level High	VH	3.3 V
Output Rising Time	TR	8.4 μ s
Output Falling Time	TF	1.9 μ s
Output Rising Delay	TDR	15 ~ 60 μ s
Output Falling Delay	TDF	3 ~ 6 μ s

With different external voltage and resistance, the corresponding current and the parameter of output logic level low are shown below.

External Voltage	External Resistance	VL	Output Current
3.3 V	1 K Ω	575 mV	2.7 mA
5 V	1 K Ω	840 mV	4.1 mA
12 V	2.4 K Ω	915 mV	4.6 mA
24 V	4.7 K Ω	975 mV	4.9 mA

I/O Electrical Feature

Line 2 Bi-direction I/O Circuit

The Line 2 bi-direction I/O circuit in camera I/O control is shown below. The Line 2 can be configured as input signal or as output signal.

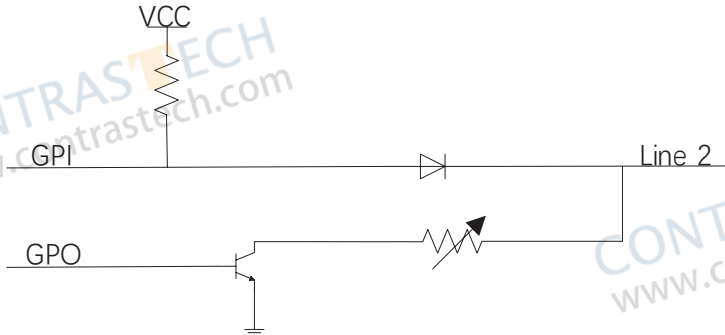

Line 2 Configured as Input

With the condition of 100 Ω and 5 VDC, the logic level and electrical feature of configuring Line 2 as output are shown below.

Input Logic Level:

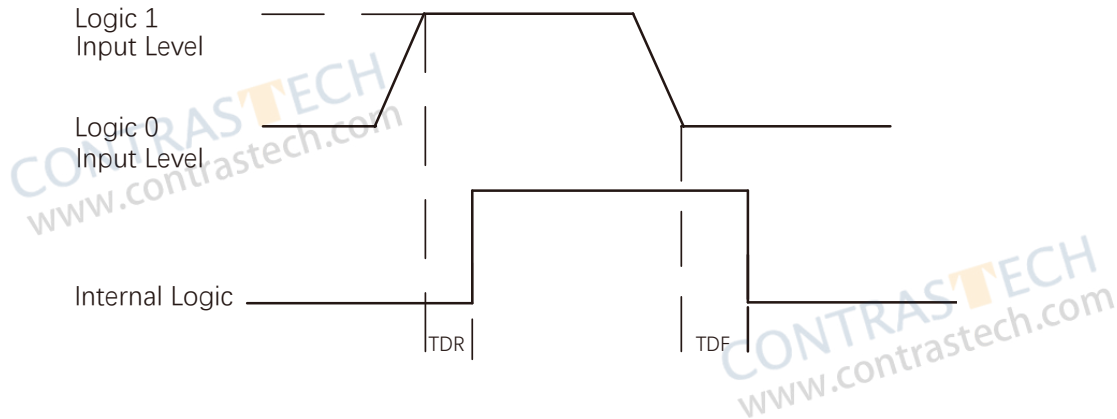

Electrical Feature of Line 2 Input:

Parameter Name	Parameter Symbol	Value
Input Logic Level Low	VL	0 ~ 0.3 VDC
Input Logic Level High	VH	3.3 ~ 24 VDC
Input Rising Time	TDR	< 1 μ s
Input Falling Time	TDF	< 1 μ s



- Make sure the input voltage is not from 0.3 VDC to 3.3 VDC as the electric status between these two values are not stable.
- The breakdown voltage is 30 VDC, and keep voltage stable.
- To prevent damage to the GPIO pin, please connect GND first and then input voltage in Line 2.

I/O Electrical Feature

Line 2 Configured as Output

The maximum current is 25 mA and the output impedance is 40 Ω .

The relation among external voltage, resistance and the output level low is shown below.

External Voltage	External Resistance	VL (GPIO2)
3.3 V	1 K Ω	160 mV
5 V	1 K Ω	220 mV
12 V	1 K Ω	460 mV
24 V	1 K Ω	860 mV
30 V	1 K Ω	970 mV

When the voltage of external resistance (1 K Ω) is pulled up to 5 VDC, the logic level and electrical feature of configuring Line 2 as output are shown below.

Output Logic Level:

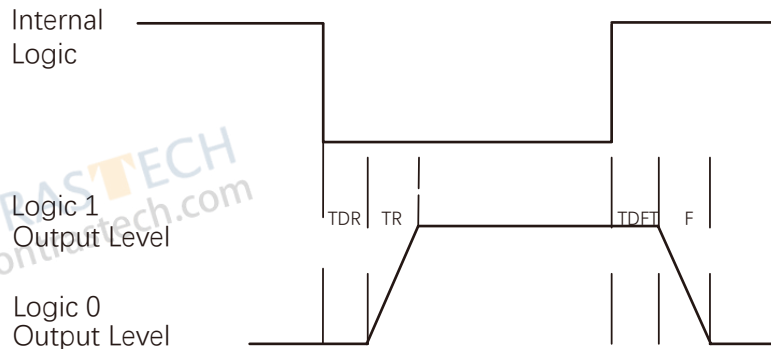

Electrical Feature of Line 2 Output:

Parameter Name	Parameter Symbol	Value
Output Logic Level Low	VL	220 mV
Output Logic Level High	VH	4.75 V
Output Rising Time	TR	0.06 μ s
Output Falling Time	TF	0.016 μ s
Output Rising Delay	TDR	0 ~ 4 μ s
Output Falling Delay	TDF	< 1 μ s

I/O Electrical Feature

■ Factors Affecting I/O Line Transmission Delay

The factors affecting the transmission delay of the I/O line are shown in the table below, where ★ is the main influence factor and ☆ is the secondary influence factor.

Factor \ Line	Opto-isolated input line	GPIO input line	Opto-isolated output line	GPIO output line
Operating Temperature	★	☆	★	☆
Differences in the production of electronic components	★	☆	★	☆
Aging	★		★	
External I/O Supply Voltage	★		★	☆
Load Resistance			★	☆
Load Current			★	☆

The following notes and suggestions are provided for each of the factors affecting I/O line transmission delay in the table above:

- Use the I/O circuits at the camera's recommended operating temperature, which is listed in the product specification.
- Applying current to the optocoupler input and output circuits causes the optocoupler to age faster; keep the current to a minimum to ensure stable transmission delays.
- To minimize low-speed transmission delay, an external I/O supply voltage of about 5 V is recommended.
- Use the recommended pull-up resistor for better fast trigger response.
- Keep the trigger input/output frequency of the circuit within the range of 10 kHz for optocoupler circuits and 1 MHz for GPIO circuits.
- To reduce the transmission delay, it is recommended to use the GPIO line, which has a shorter transmission delay than the optocoupler delay, but the GPIO line has a risk of burnout, so please use it with caution.
- Trigger signal jitter may cause the internal camera jitter to increase, to avoid jitter, keep the trigger signal edge steep so as to minimize the internal camera jitter (preferably below 1 μ s).

I/O Wiring

The camera has different appearance with varied models. Here mainly introduces how to wire the I/O part of the camera.

Other cameras can be analogized according to the cable definition in the wiring diagram, combined with the power supply and I/O interface definition chapter.

Line 0 Wiring

When the camera uses Line 0 as hardware trigger source, wirings are different with different external devices of input signal.

The input signal is PNP Device, that is, Line 0 Connecting to PNP Device:

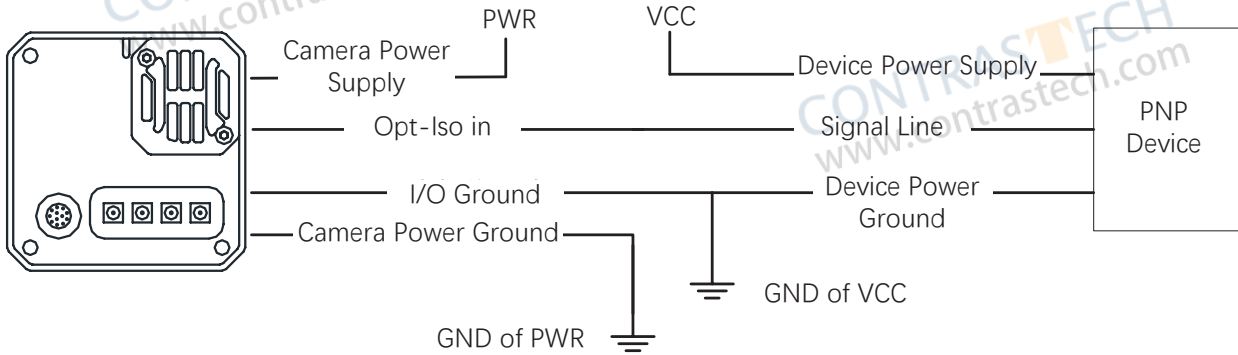

The input signal is NPN Device, that is, Line 0 Connecting to NPN Device:

_If the VCC of NPN device is 24 VDC, and it is recommended to use 4.7 K Ω pull-up resistor.

_If the VCC of NPN device is 12 VDC, and it is recommended to use 1 K Ω pull-up resistor.

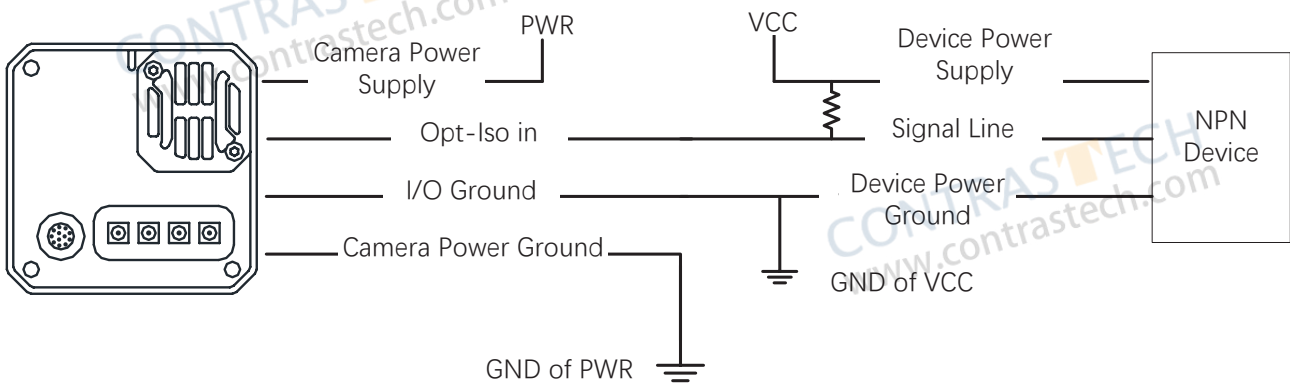

The input signal is Switch, that is, Line 0 Connecting to a Switch:

If the VCC of switch is 24 VDC, and it is recommended to use 4.7 K Ω resistor to protect circuit.

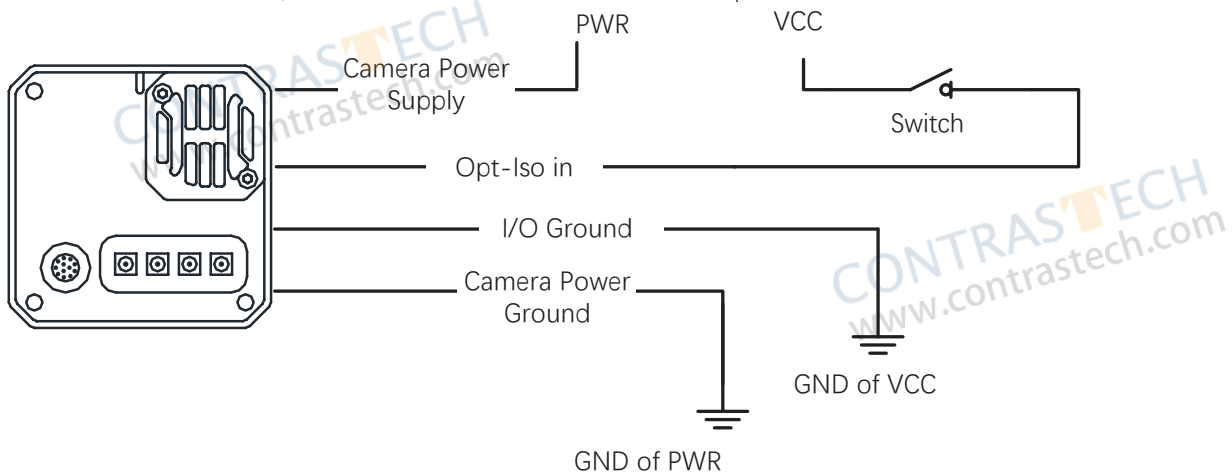

I/O Wiring

Line 1 Wiring

When the camera uses Line 1 as output signal, wirings are different with different external devices.

The external devices is PNP Device, that is, Line 1 Connecting to PNP Device:

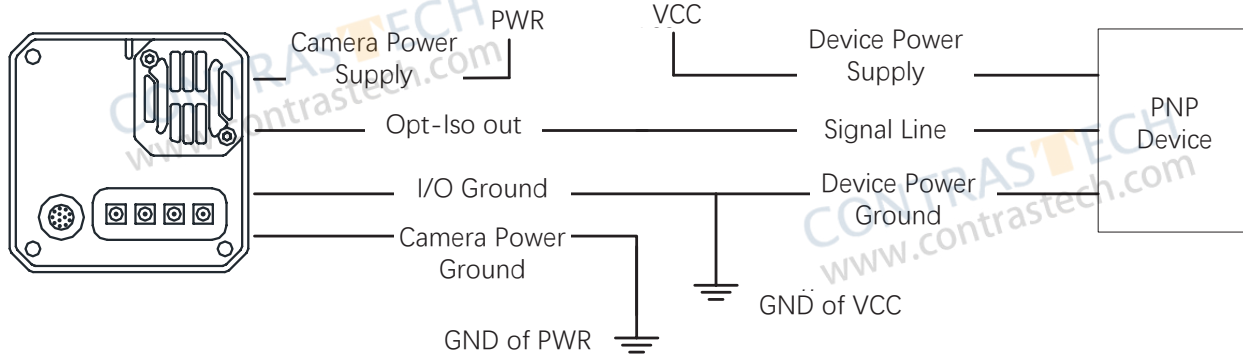

The external devices is NPN Device, that is, Line 1 Connecting to NPN Device:

_If the VCC of NPN device is 24 VDC, and it is recommended to use 4.7 K Ω pull-up resistor.

_If the VCC of NPN device is 12 VDC, and it is recommended to use 1 K Ω pull-up resistor.

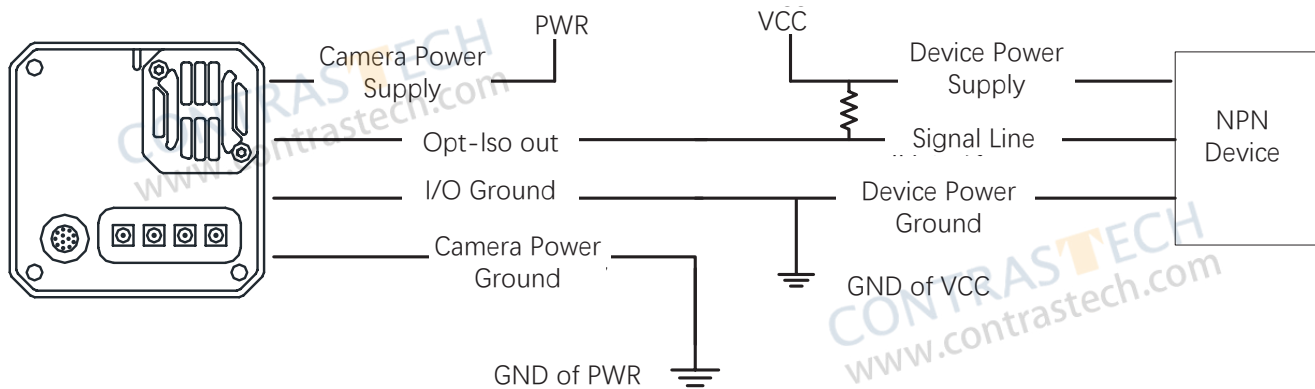

I/O Wiring

Line 2 Wiring

As bi-direction I/O Circuit, Line 2 can be used as both input signal and output signal.

Line 2 Configured as Input

When the camera uses Line 2 as hardware trigger source, wirings are different with different external devices of input signal. The input signal is PNP Device, that is, Line 2 Connecting to PNP Device as Input: It is recommended to use 330 Ω pull-down resistor.

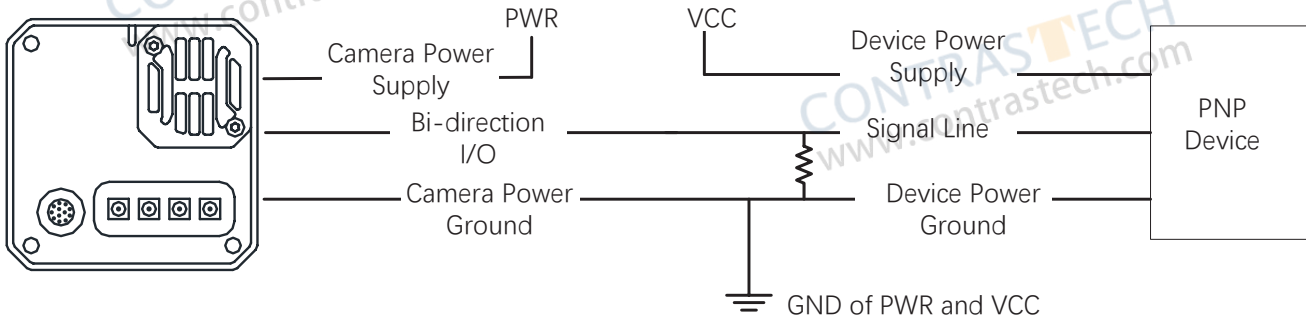

The input signal is NPN Device, that is, Line 2 Connecting to NPN Device as Input:
 _If the VCC of NPN device is 24 VDC, and it is recommended to use 4.7 K Ω pull-up resistor.
 _If the VCC of NPN device is 12 VDC, and it is recommended to use 1 K Ω pull-up resistor.

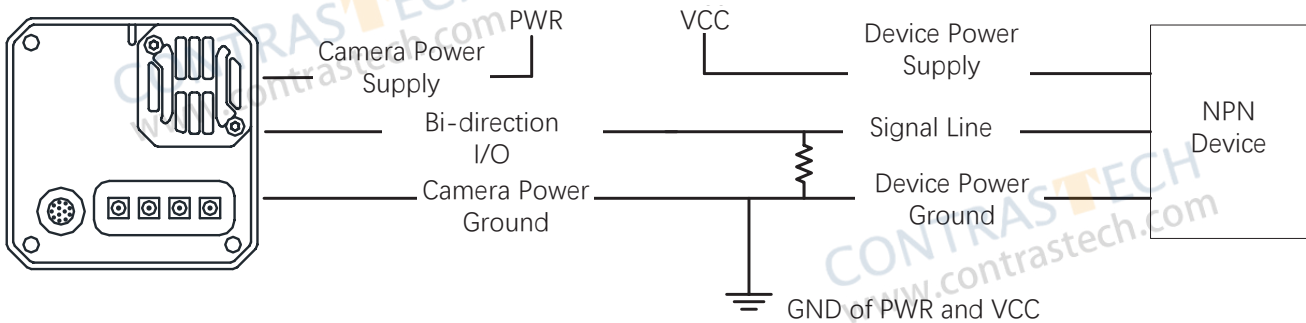

The input signal is Switch, that is, Line 2 Connecting to a Switch as Input:
 The switch value can provide low electrical level to trigger line 2.

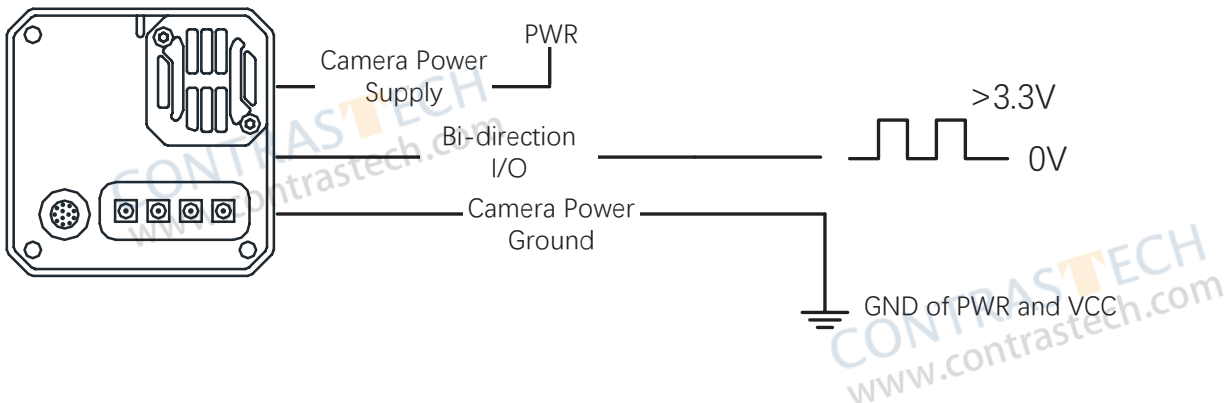

I/O Wiring

Line 2 Configured as Output

When the camera uses Line 2 as output signal, wirings are different with different external devices.

The external devices is PNP Device, that is, Line 2 Connecting to PNP Device as Output:

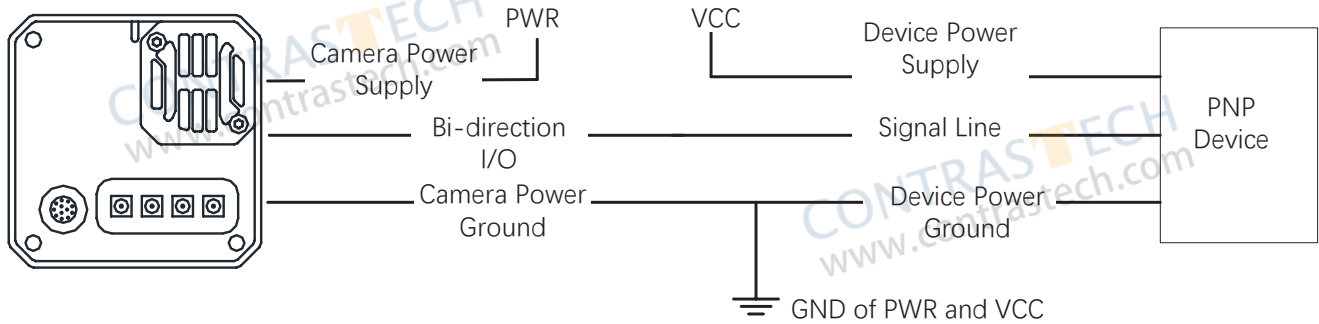

The external devices is NPN Device, that is, Line 2 Connecting to NPN Device as Output:

_If the VCC of NPN device is 24 VDC, and it is recommended to use 4.7 K Ω pull-up resistor.

_If the VCC of NPN device is 12 VDC, and it is recommended to use 1 K Ω pull-up resistor.

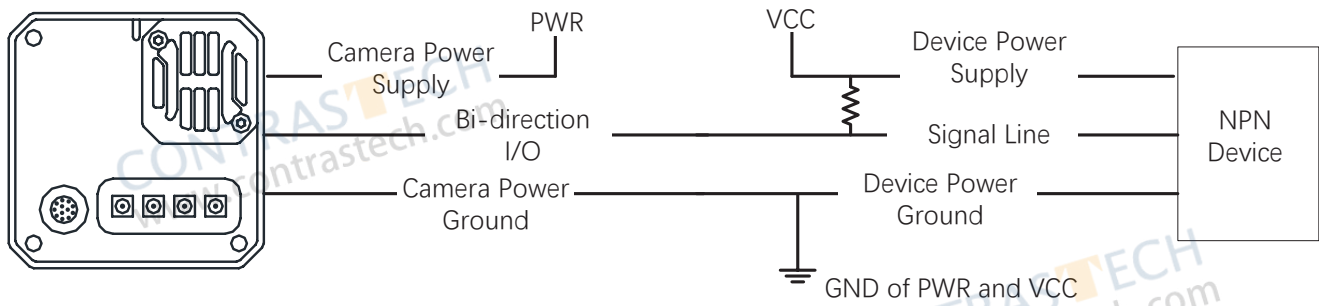

CHAPTER 8 IMAGE PARAMETER

Resolution and ROI

The camera displays the image with max. resolution by default. Click Image Format Control, and view Width Max and Height Max. Width Max stands for the max. pixels per inch in width direction and Height Max stands for the max. pixels per inch in height direction.

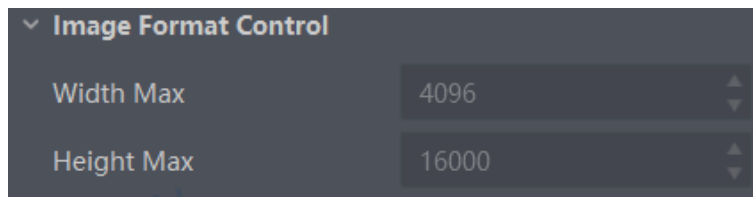

If you are only interested in a certain region of the image, you can set a Region of Interest (ROI) for the camera. Setting Region of Interest can reduce the bandwidth of the image being transmitted. Thus increasing the frame rate to some extent.



The camera currently supports 1 ROI only, that is, there is Region 0 for Region Selector parameter only.

Click Image Format Control > Region Selector, and enter Width, Height, Offset X, and Offset Y.

- Width: it stands for horizontal resolution in ROI area.
- Height: it stands for vertical resolution in ROI area.
- Offset X: it refers to the horizontal coordinate of the upper left corner of the ROI.
- Offset Y: it refers to the vertical coordinate of the upper left corner of the ROI.

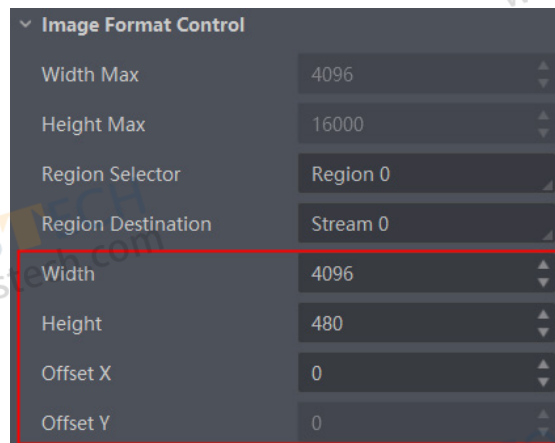

- The Width value plus Offset X value should not be larger than Width Max parameter value, Height value plus Offset Y value should not be larger than Height Max parameter value.
- The ROI function may differ by camera models.

Image Reverse

There are two types of Image Reverse, Reverse X and Reverse Y. The principle and parameter of Image Reverse are shown below.

Image Reverse	Parameter	Principle
Reverse X	Image Format Control > Reverse X	the image reverses in a horizontal way
Reverse Y	Image Format Control > Reverse Y	the image reverses in a vertical way

You can click Image Format Control, and enable Reverse X or Reverse Y according to actual demands.

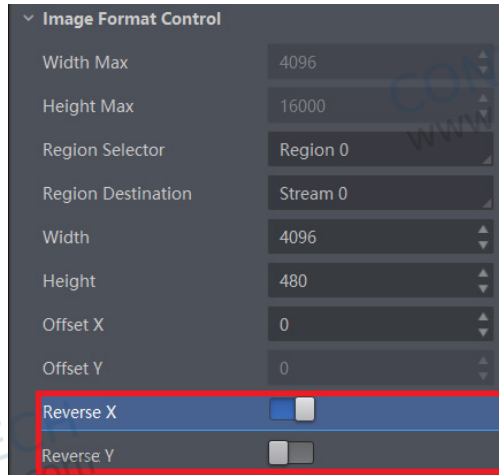

The image reverse function may differ by camera models.

Pixel Format

The pixel format may differ by camera models.

The relation among ADC bit depth, pixel format and pixel size is shown below. Click Image Format Control > Pixel Format, and set Pixel Format according to actual demands.

ADC Bit Depth	Pixel Format	Pixel Size (Bits/Pixel)	
8	Mono 8	8	
	Mono 8、Bayer 8	8	
	Mono 10、Bayer 10	10	
	Mono 12、Bayer 12	12	
12	RGB 8	24	
	16	Mono 8、Bayer 8	8
		Mono 10、Bayer 10	10
		Mono 12、Bayer 12	12
		Mono 16、Bayer 16	16
RGB 8	24		



- The specific pixel formats may differ by device models.
- With different ADC bit depth, the pixel format and pixel size may differ.

Pixel Format

The default output data format of mono device is Mono 8. The default output data format of color device is Bayer 8, and it can be converted into RGB format via pixel interpolation algorithm. Bayer GR, Bayer GB, Bayer BG, Bayer RG and Bayer RBGG patterns are shown below.



Bayer GR Pixel Pattern

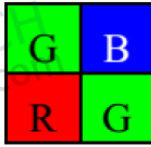

Bayer GB Pixel Pattern

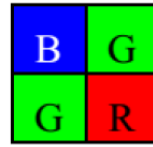

Bayer BG Pixel Pattern

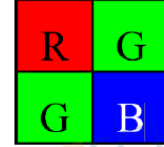

Bayer RG Pixel Pattern

Set Pixel Format:

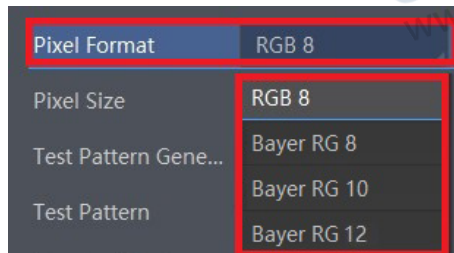

Test Pattern

The camera supports test pattern function. When there is exception in real-time image, you can check whether image of test mode have similar problem to determine the reason. This function is disabled by default, and at this point, the outputted image by the camera is real-time image. If this function is enabled, the outputted image by the camera is test image.

Click Image Format Control > Test Pattern, and set Test Pattern according to actual demands

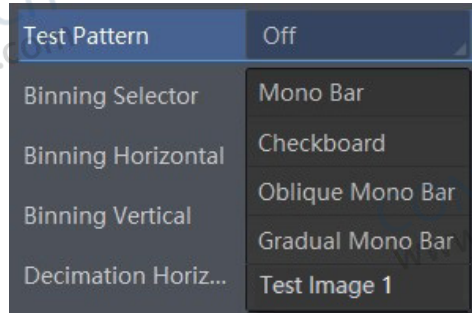

The mono camera offers 5 test patterns, including Mono Bar, Checkboard, Oblique Mono Bar, Gradual Mono Bar, and Test Image 1. The color camera offers 7 test patterns, including Mono Barr, Checkboardr, Oblique Mono Barr, Gradual Mono Barr, Vertical Color Barr, Horizontal Color Barr, Test Image 1.



The pattern of the test image 1 may differ by camera models.

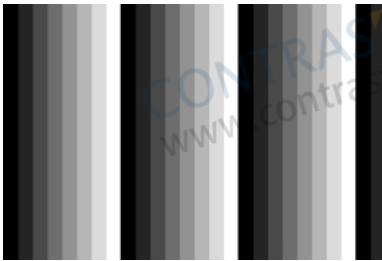

Fig:Mono Bar

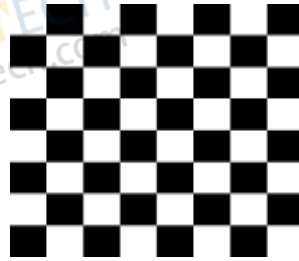

Fig:Checkboard

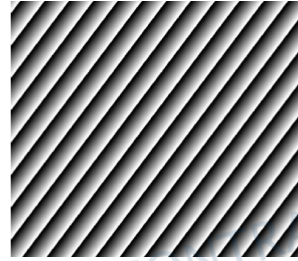

Fig:Oblique Mono Bar

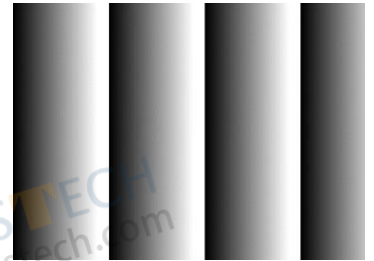

Fig:Gradual Mono Bar



Fig:Vertical Color Bar



Fig:Horizontal Color Bar



Fig:Test Image 1

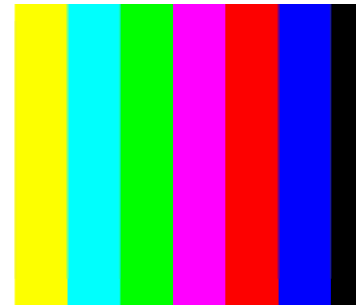

Binning

The purpose of setting binning is to enhance sensibility. With binning, multiple sensor pixels are combined as a single pixel to reduce resolution and improve image brightness.

For color cameras, the camera horizontally merges the pixel values of adjacent pixels of the same color, as shown below.

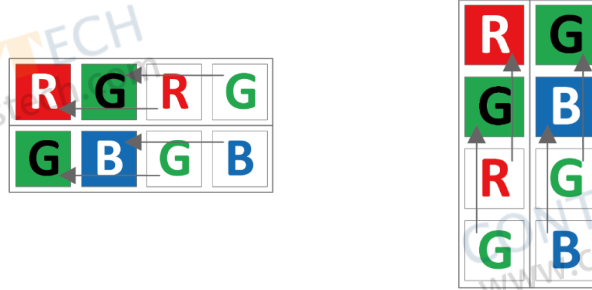

When the Horizontal Binning Coefficient and Vertical Binning Coefficient of the color camera are both set to 2, the camera combines four neighboring sub-pixels of the same color according to the corresponding positions and outputs the combined pixel value as a sub-pixel, as shown in the following figure.

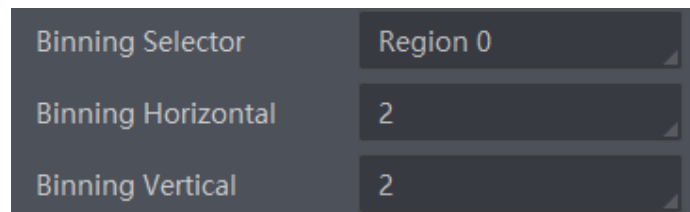

Click Image Format Control, and set Binning Horizontal and Binning Vertical according to actual demands.

Binning Horizontal refers to the image's width, and Binning Vertical refers to the image's height.



The binning function may differ by camera models.

Decimation

The decimation feature allows you to reduce the number of sensor pixel columns or rows that are transmitted by the camera. This procedure is also known as "subsampling". It reduces the amount of data to be transferred and may increase the camera's frame rate.

Click Image Format Control, and set Decimation Horizontal and Decimation Vertical according to actual demands.

Decimation Horizontal refers to the image's width, and Decimation Vertical refers to the image's height.

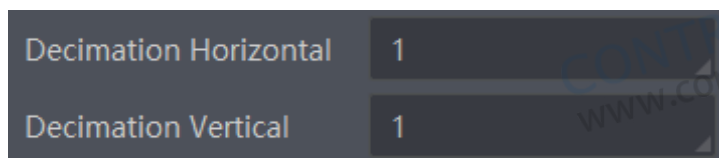

The decimation function may differ by camera models.

Exposure Time

The device supports 2 types of exposure modes, including Timed and Trigger Width.

- If the Exposure Mode is Timed, the device's exposure time is controlled by Exposure Auto and Exposure Time.
- When the device's Trigger Mode is On, Trigger Source is Line 0 or Line 2, and Trigger Activation is Level High or Level Low, Trigger Width can be selected as Exposure Mode and the device's exposure time is controlled by the signal duration.

The exposure mode may differ by device models.

The device offers 2 types of exposure time modes, including Ultrashort mode and Standard mode.

■ Standard Exposure Time Mode

In standard exposure time mode, the device supports 3 types of exposure mode, including Off, Once and Continuous. Click Acquisition Control → Exposure Auto, and select Exposure Auto according to actual demands.

Exposure Method	Parameter	Principle
Off	Acquisition Control > Exposure Auto	The camera exposures according to the value configured by user in Exposure Time.
Once		Adjust the exposure time automatically according to the image brightness. After adjusting, it will switch to Off Mode.
Continuous		Adjust the exposure time continuously according to the image brightness.



- If the device is under Continuous exposure mode, once external trigger mode is enabled, the device will automatically switch to Off exposure mode.
- Some models of the device do not support Once or Continuous exposure mode. You can enter Exposure Time (μ s) directly.

When the exposure mode is set as Once or Continuous, the exposure time should be within the range of Auto Exposure Time Lower Limit (μ s) and Auto Exposure Time Upper Limit (μ s).

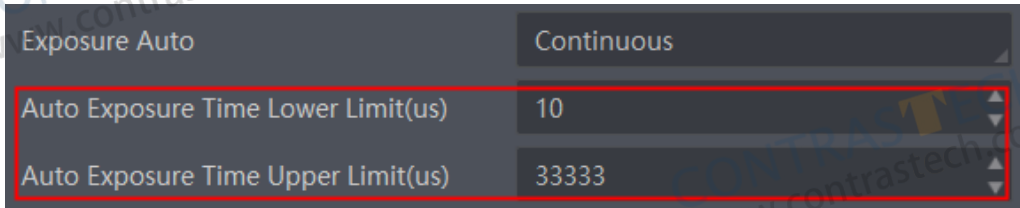

■ Ultrashort Exposure Time Mode

Go to Acquisition Control → Exposure Time Mode, and set Exposure Time Mode according to actual demands.

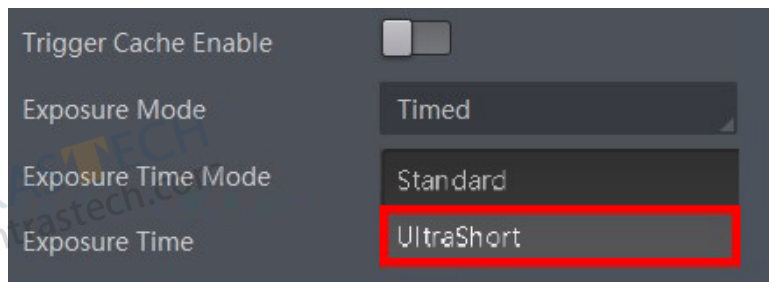

- The exposure time mode may differ by device models.
- If the device you got does not support Ultrashort exposure time mode, and then there is no Exposure Time Mode parameter, and your device supports Standard exposure time mode only by default.

HDR

The device supports HDR (High Dynamic Range) function that the device acquires images based on customized settings, and each with its own exposure time, gain and white balance.

Step:

1. Go to Acquisition Control → HDR Enable, and enable HDR Enable.
2. Set HDR Number to determine how many groups to join HDR according to actual demands.



- Up to 8 HDR groups can be configured.
- The HDR function may differ by device models.

3. Set HDR Selector, and set corresponding HDR Shutter, HDR Gain and HDR Balance R/G/B.



Only some color device models support HDR Balance Ratio R/G/B.

4. (Optional) Click Execute in HDR Reset to reset HDR parameters.

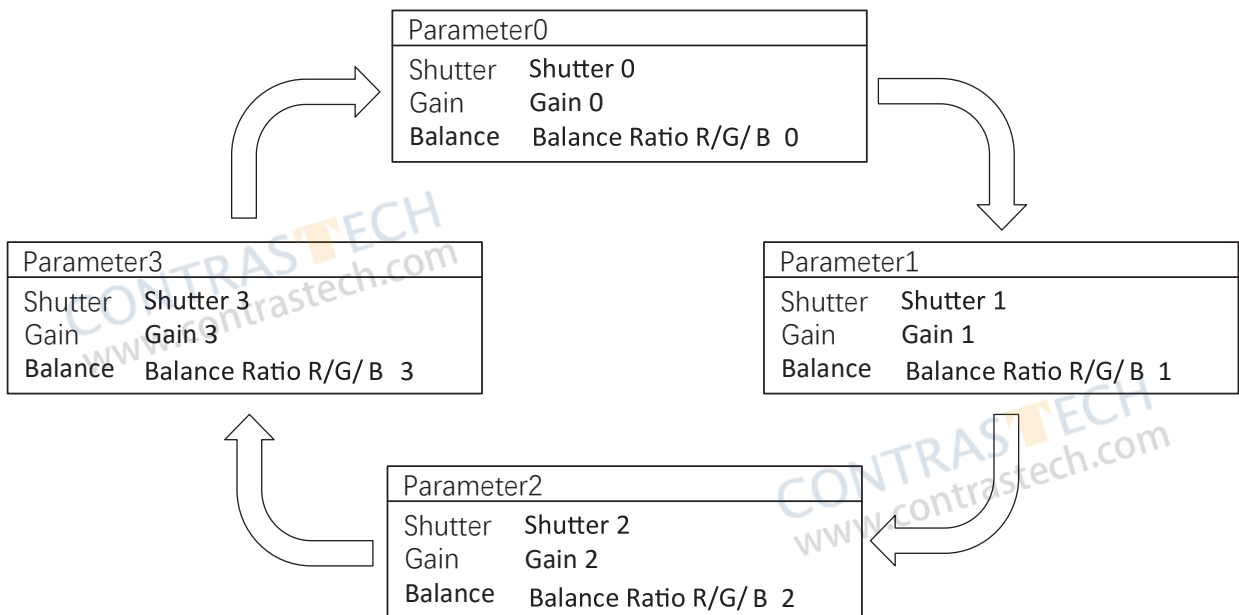

Gain

The camera has 2 types of gain, including the analog gain and digital gain. The analog gain is applied before the signal from the camera sensor is converted into digital values, while digital gain is applied after the conversion.



The gain function may differ by device models.

■ Analog Gain

The analog gain parameter name may differ for camera of different models or firmware. The analog gain parameter name can be Preamp Gain or Gain, which have different settings method.

- Preamp Gain

Click Analog Control > Preamp Gain, and set Preamp Gain according to actual demands.



When the analog gain parameter is Preamp Gain, you can set it manually only.

- Gain: The camera has 3 types of analog gain: Off, Once and Continuous. The analog gain mode and principle are shown below.

Gain Mode	Parameter	Principle
Off	Analog Control > Gain Auto	The camera adjusts gain according to the value configured by user in Gain.
Once		Adjust the gain automatically according to the image brightness. After adjusting, it will switch to Off Mode.
Continuous		Adjust the gain continuously according to the image brightness.

When the gain mode is set as Once or Continuous, the gain should be within the range of Auto Gain Lower Limit (dB) and Auto Gain Upper Limit (dB).

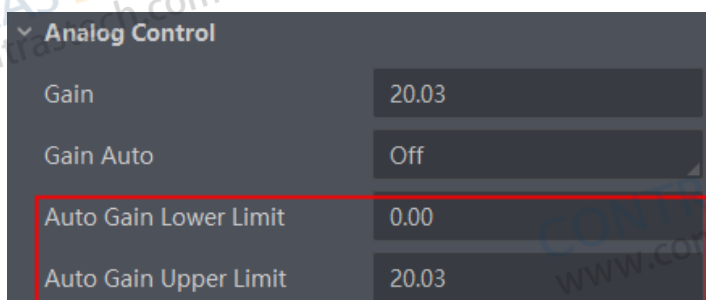

- When increasing gain, the image noise will increase too, which will influence image quality. If you want to increase image brightness, it is recommended to increase the device's exposure time first. If the exposure time reaches its upper limit, and at this point, you can increase gain.
- Some models of the device do not support Once or Continuous gain mode. You can enter Gain (dB) directly.

■ Digital Gain

Apart from analog gain, the camera also supports digital gain function. When analog gain reaching its upper limit and the image is still too dark, it is recommended to improve image brightness via digital gain. You can set digital gain as shown below.

Click Analog Control > Digital Shift Enable, check Digital Shift Enable to enable it, and enter proper value in Digital Shift according to actual demands.

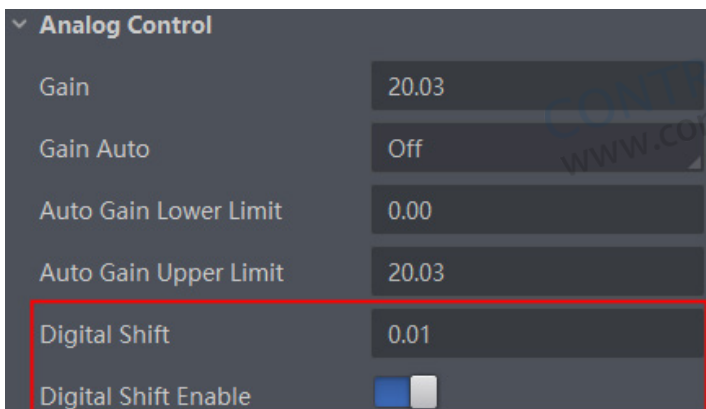

When increasing the digital gain, the image noise will greatly increase too, which will severely influence image quality. It is recommended to use analog gain first, and then to adjust digital gain if the analog gain cannot meet demands.

Brightness

The camera brightness refers to the brightness when the camera adjusts image under Once or Continuous exposure mode, or Once or Continuous gain mode. You can set brightness as shown below.

You should enable Once or Continuous exposure mode, or Once or Continuous gain mode first before setting brightness. Click Analog Control > Brightness, and set Brightness according to actual demand, and its range is from 0 to 255.

After setting brightness, the camera will automatically adjust exposure time to let image brightness reach target one. Under Once or Continuous exposure mode, or Once or Continuous gain, the higher the brightness value, the brighter the image will be. Go to Analog Control → Brightness, and enter Brightness according to actual demand.

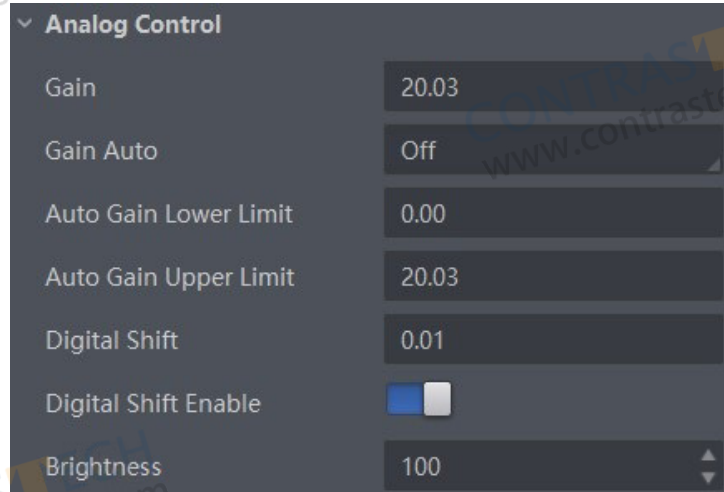

Black Level

The camera supports black level function that allows you to change the overall brightness of an image by changing the gray values of the pixels by a specified amount.

Click Analog Control > Black Level Enable, enable Black Level Enable, and enter Black Level according to actual demands. The range of black level is from 0 to 4095.

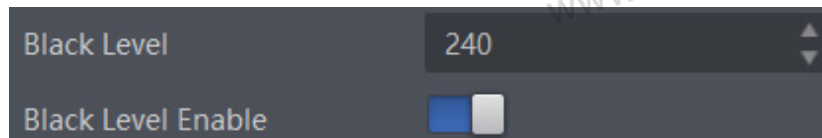

The black level function may differ by camera models.

White Balance

White balance is only available for color cameras.

The white balance refers to the camera color adjustment depending on different light sources. Adjust the Gain Value of the image's R channel and B channel to keep white regions white under different color temperatures. Ideally, the proportion of R channel, G channel and B channel in the white region is 1:1:1.

Click Analog Control > Balance White Auto, and select Balance White Auto according to actual demands.

The camera supports 3 types of white balance modes: Off, Once and Continuous.

White Balance Mode	Parameter	Principle
Off	Analog Control > Balance White Auto	You need to set the R, G, B value manually, between 1 and 4095. 1024 means ratio is 1.0
Once		Automatic white balance once. Adjust the white balance for a certain amount of time then stop. It implements an algorithm that finds possible gray areas in the Bayer data.
Continuous		Continuous automatic white balance. It implements an algorithm that finds possible gray areas in the Bayer data.

It is recommended to correct white balance when there is great difference between the camera's color effect and actual effect. You can correct white balance as shown below.

Steps:

1. Put a white paper in the range of the camera's field of view, and make sure the paper covers the entire field of view.
2. Set exposure and gain. It is recommended to set image brightness value between 120 and 160.
3. Select Once as Balance White Auto, and the camera will automatically adjust white balance for once.

Balance White Auto parameter defaults to Continuous, and AWB Color Temperature Mode is Narrow. If the color effect of the image is still not good after performing automatic white balance in this color temperature mode, you can set the AWB Color Temperature Mode parameter to Wide and then perform automatic white balance correction.

If there is still great difference between correction effect and actual color, it is recommended to correct white balance according to following steps.

Steps:

	<ul style="list-style-type: none"> ■ Here we take Green as an example. For specific Balance Ratio Selector value, please refer to the actual condition. ■ In order to avoid repeated correction after rebooting the device, it is recommended to save white balance parameter to User Set after white balance correction. You can refer to the Section Save and Load User Set for details. ■ If the light source and color temperature in environment change, you need to correct white balance again.
--	---

1. Select Off as Balance White Auto. At this time, Balance Ratio is 1024.
2. Find corresponding R/G/B channel in Balance Ratio Selector. Here we take Green as an example.
3. Find camera's R/G/B value.
4. Take Green as correction standard, and manually adjust other two channels (R channel and B channel) to let these three channels have same value.

Gamma Correction

The camera supports Gamma correction function. Generally, the output of the camera's sensor is linear with the photons that are illuminated on the photosensitive surface of the sensor. Gamma correction provides a non-linear mapping mechanism as shown below.

- Gamma value between 0.5 and 1: image brightness increases, dark area becomes brighter.
- Gamma value between 1 and 4: image brightness decreases, dark area becomes darker.

 Gamma correction is not supported under Bayer format for color cameras.

Gamma Curve

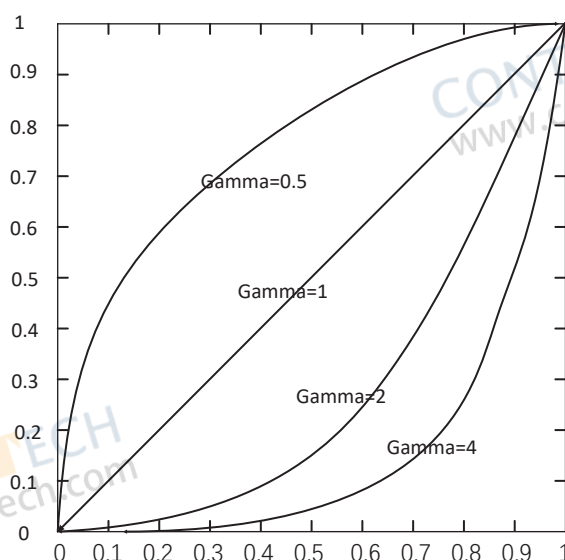

There are 2 types of Gamma correction, including User mode and sRGB mode.

User is a user-defined mode, which can set the value of Gamma; sRGB is a standard protocol mode.

■ You can set User mode as shown below.

1. Click Analog Control > Gamma Selector.
2. Select User as Gamma Selector.
3. Enable Gamma Enable.
4. Enter Gamma according to actual demands, and its range is from 0 to 4.

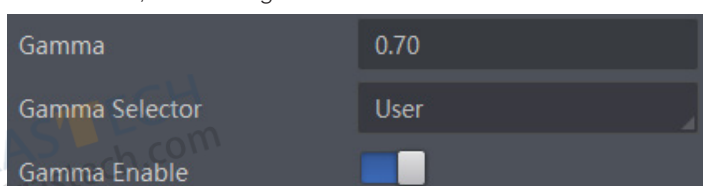

■ You can set sRGB mode as shown below.

1. Click Analog Control > Gamma Selector.
2. Select sRGB as Gamma Selector.
3. Enable Gamma Enable.

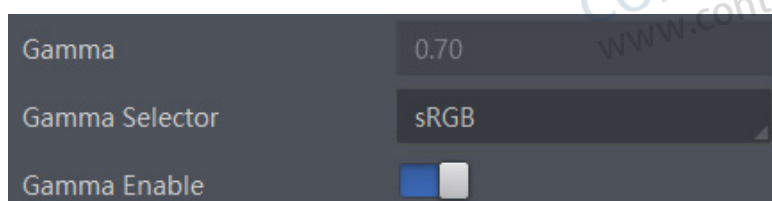

Sharpness

The camera supports sharpness function that can adjust the sharpness level of the image edge, and this function is disabled by default.



The sharpness function is available when the camera is in Mono and YUV pixel format.

Click Analog Control > Sharpness Enable, enable Sharpness Enable, and enter Sharpness according to actual demands. The range of the brightness is from 0 to 100.

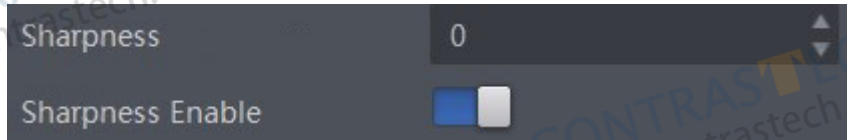

AOI

The camera supports AOI function that can adjust the brightness and white balance of the entire image based on the area you selected.

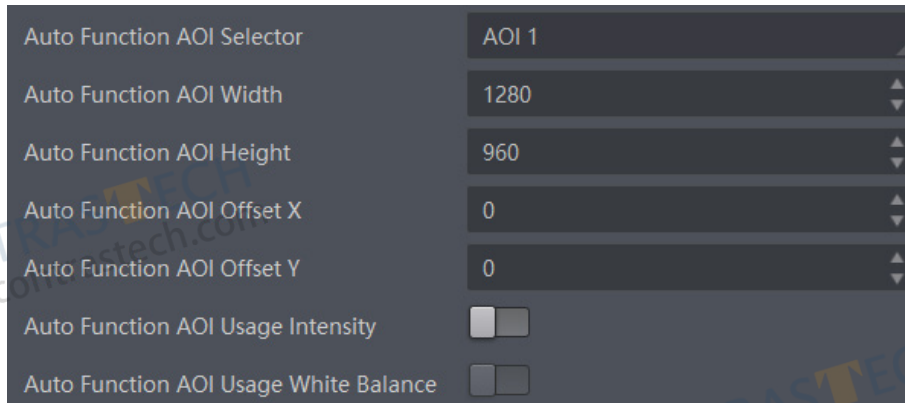

The AOI 1 function needs to be used in the camera's Auto Exposure Time Mode, and the AOI 2 function needs to be used in the camera's Auto White Balance Mode.

Steps:

1. Click Analog Control > Auto Function AOI Selector, and select AOI 1 or AOI 2 Auto Function AOI Selector.
2. Enter Auto Function AOI Width, Auto Function AOI Height, Auto Function AOI Offset X, and Auto Function AOI Offset Y according to actual demands.
3. Enable Auto Function AOI Usage Intensity if AOI 1 is selected as Auto Function AOI Selector. Or enable Auto Function AOI Usage White Balance if AOI 2 is selected as Auto Function AOI Selector.

Color Transformation Control

The color transformation control is used to restore color and eliminate the overlap in the color channels.

Click Color Transformation Control, select Color Transformation Value Selector, set Color Transformation Value according to actual demand, and check Color Transformation Enable.



- The function of color transformation control is only available for color cameras.
- Currently, RGB to RGB is available for Color Transformation Selector only.

Hue

The hue is the reference hue when the color correction function is enabled in the non-mono format of the color camera, and the overall tendency of the colors in the image can be adjusted.

The hue is set by the Hue parameter under the Color Transformation Control property, and the range is 0 ~ 255.

After setting Hue, the camera will perform color correction according to the Hue value to make the image tone reach the target value. For example, when Hue is set to 128, the red in the image appears as real red; when Hue is 0, the hue is reversed 128 degrees counterclockwise, and red becomes blue; when Hue is 255, the hue rotates clockwise At 128 degrees, red becomes green.

Adjusting the hue shifts the colors of the image.

- Steps:
1. Click Color Transformation Control, and enable Color Transformation Enable. Make sure the camera's pixel format is Bayer, YUV, RGB or BGR.
 2. Enable Hue Enable, and enter Hue according to actual demands.



- Hue is only available for color cameras.
- Hue setting method may differ by camera models. For some models, go to Analog Control, enable Hue Enable, and enter Hue according to actual demands.

Saturation

The saturation is the reference saturation when the color correction function is enabled in the non-mono format of the color camera. The brightness of the colors in the image can be adjusted to make the image look fuller, more colorful, and closer to the real thing.

The smaller the set value, the darker the image will look; the larger the set value, the fuller and brighter the image will look.

Adjusting the saturation changes the colorfulness of the colors. A higher saturation, for example, makes colors easier to distinguish.

- Steps:
1. Click Color Transformation Control, and enable Color Transformation Enable. Make sure the camera's pixel format is Bayer, YUV, RGB or BGR.
 2. Enable Saturation Enable, and enter Saturation according to actual demands.

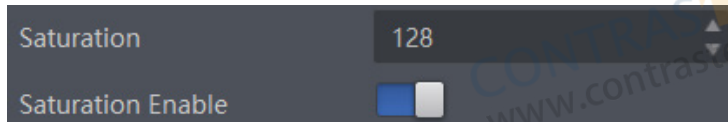

- Saturation is only available for color cameras.
- Saturation setting method may differ by camera models. For some models, go to Analog Control, enable Saturation Enable, and enter Saturation according to actual demands.

LUT

A Look-Up Table (LUT) is a customized grayscale-mapping table. The LUT allows you to replace the pixel values in your images by values defined by you.

- Steps:
1. Click LUT Control, and enable LUT Enable.
 2. Enter LUT Index according to actual demands, and its range is from 0 to 1023.
 3. Enter LUT Value according to actual demands, and its range is from 0 to 4095.

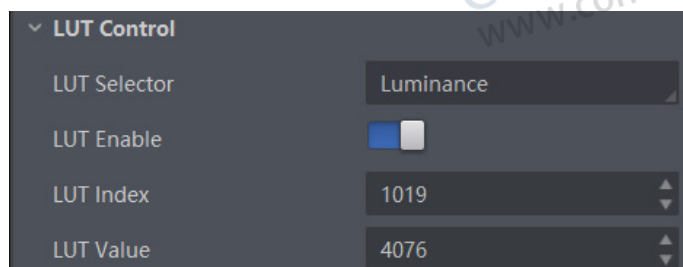

You cannot use Gamma correction function and LUT function at the same time.

Shading Correction

The camera supports shading correction function that improves the image uniformity when you acquire a non-uniformity image due to external conditions. The shading correction type includes LSC correction, FFC correction, NUC correction, FPNC correction, and PRNUC correction.



The specific shading correction types that devices support and configuration methods may differ by device models.

■ LSC Correction

LSC correction stands for Lens Shading Correction that eliminates non-uniform illumination brought by lens. The LSC correction supports two correction methods, including auto image correction or correcting image via setting parameters.



- LSC correction can be done when only the camera is in full resolution.
- The specific LSC correction method that devices support may differ by device models.

Auto Image Correction

Steps:

- _ Click Shading Correction, select LSC Correction as Shading Selector.
- _ Click Execute in Activate Shading.
- _ Check LSC Enable to enable it.

Correcting Image via Setting Parameters

Some device models support correcting image via setting parameters to adjust the image brightness according to different scenarios.

Steps:

- _ Click Shading Correction, select LSC Correction as Shading Selector.
- _ Select tables from LSC Table Selector ranging from Table 0 to Table 7 according to actual demands.
- _ Enable LSC Target Enable and set LSC Target R/G/B according to actual demands.



- The larger value configured in LSC Target R/G/B, and brighter the image is.
- The function of LSC Target Enable and LSC Target is only valid before executing Activate Shading.

- _ Click Execute in Activate Shading, and enable LSC Enable.



The LSC correction can be done only when the device is in full resolution. If you are only interested in certain details in the image, you can use the ROI function.

■ LSC Sequencer

Without stopping device's image streams, LSC sequencer function can periodically take pictures of collected images via setting multiple groups of brightness parameter tables according to the default sequencer parameter group or manually setting sequencer parameter group. Therefore, the device can process images of inconsistent uniformity due to different light sources.



The LSC sequencer function may differ by device models.

Steps:

- _ Click Shading Correction, and select LSC Correction as Shading Selector.
- _ Select tables from LSC Table Selector ranging from Table 0 to Table 7 according to actual demands.



When using eight LSC tables, the default sequencer order is from Table 0 to Table 7 in turn.

- _ Enable LSC Target Enable and set LSC Target.



- The larger value configured in LSC Target R/G/B, and brighter the image is.
- The function of LSC Target Enable and LSC Target is only valid before executing Activate Shading.

- _ Click Execute in Activate Shading, and enable LSC Sequencer Enable.
- _ Set LSC Sequencer Number to configure how many tables to participate the sequencer.
- _ (Optional) Click Execute in LSC Sequencer Reset to reset the sequencer.
- _ (Optional) Enable LSC Sequencer Manual Enable if you need to set the sequencer order manually, and set LSC Sequencer Selector and LSC Sequencer Table according to actual demands.

Shading Correction

■ FFC Correction

The flat field correction (FFC) is used to improve the image uniformity that may be impacted by the sensor, light sources, external conditions, etc. The FFC correction supports two correction methods, including auto image correction or correcting image via setting parameters.



The FFC correction can be done only when the device is in full resolution.

Steps:

- _ Click Shading Correction, and select FFC Correction as Shading Selector.
- _ Click Execute in Activate Shading, and enable FFC Enable.

■ User PRNUC Correction

The device currently supports user PRNUC (Photo-response Non-Uniformity Correction) function that eliminates vertical line on the images.

Steps:

- _ Click Shading Correction, and click Execute in Activate Shading.
- _ Enable NUC Enable, and PRNUC Enable will be enabled automatically.

■ Other Corrections

Other corrections include FPNC and PRNUC. Click Shading Correction, and enable NUC Enable. The FPNC Enable and PRNUC Enable will be automatically enabled or disabled according to the device's condition.

FTO Mode

FTO (Four to One) mode enables the device to combine four acquired images to one image of 604 MP, as shown below.

Go to Image Format Control, and enable FTO Mode according to actual demands.

After enabling FTO mode, the device has pixel shifting function. This function shifts the image sensor to X and Y direction precisely using the 2D-Stage. The resulting image can be combined of 4 individual images captured by shifting the image sensor to X and Y direction. Thus, the output image offers improved resolution (4 Shot Result Image) in comparison with standard output image (1 Shot Result Image).

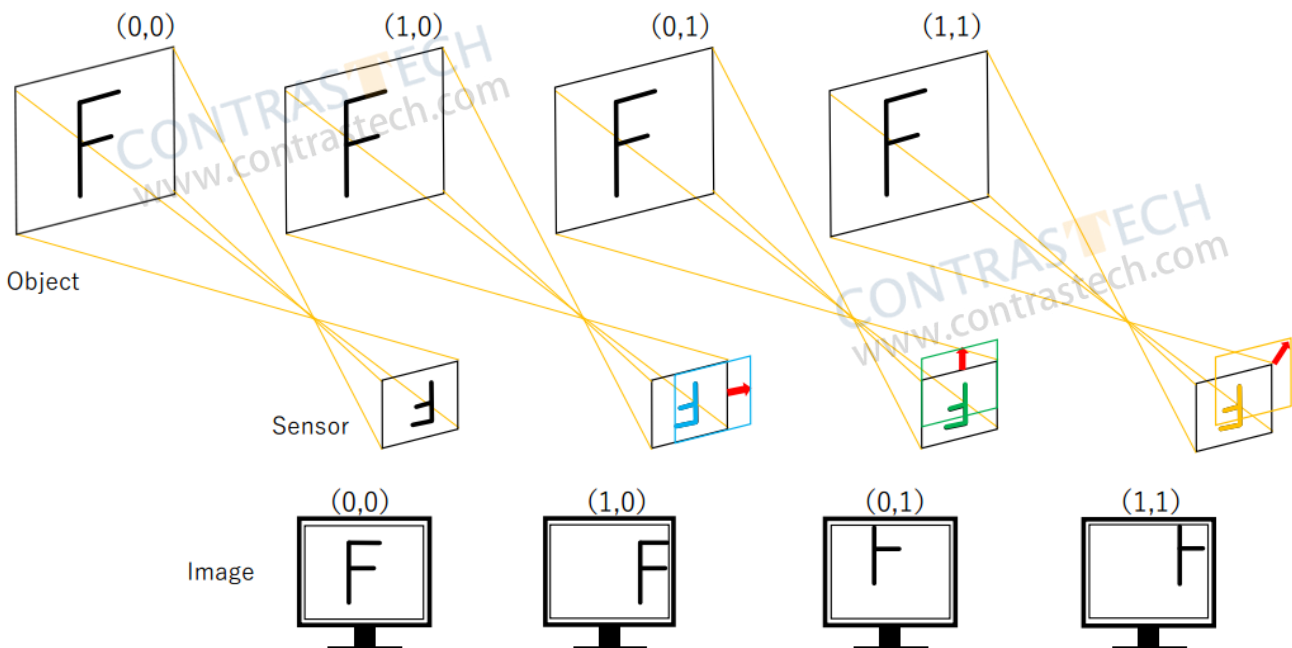

CHAPTER 9 OTHER FUNCTIONS

Device Control

In the Device Control attribute, you can view device information, edit device name, reset device, etc. The specific parameters in Device Control attribute are shown below.

Parameter	Read/Write	Description
Device Scan Type	Read only	It is the scan type of the sensor.
Device Vendor Name	Read only	It is the name of device manufacturer.
Device Model Name	Read only	It is the device model.
Device Manufacturer Info	Read only	It is the manufacturer information.
Device Version	Read only	It is the device version.
Device Firmware Version	Read only	It is the device firmware version.
Device Serial Number	Read only	It is the device serial number.
Device User ID	Read and write	Device name and it is empty by default. You can set according to your preference. <ul style="list-style-type: none"> ● If User ID is empty, the client software displays the device model. ● If you set it, the client software displays the User ID you set.
Device Revision	Read only	It is CoaXPress protocol version.
Device Manifest Size	Read only	It is the quantity of GenICam XML in the camera.
Device Manifest Selector	Read and write	It is the current ID of GenICam XML.
Device Xml Version	Read only	It is the version of GenICam XML.
Device Schema Version	Read only	It is the structure version of GenICam.
Device Uptime(s)	Read only	It is the period of time when device is powered up.
Board Device Type	Read only	It is the device type.
TEC Enable	Read and write	Check it to enable TEC function.
TEC Temperature	Read and write	It sets the max. temperature of sensor. If actual sensor's temperature is lower than this parameter, and TEC function is not enabled. If actual sensor's temperature is higher than this parameter and TEC enable is enabled, and then TEC function is enabled.
Device Temperature Selector	Read and write	It selects device temperature, including sensor and mainboard.
Device Temperature	Read only	It displays the real-time temperature of the device component you selected in Device Temperature Selector.
Sensor Board Temperature	Read only	It displays the real-time temperature of the device's sensor you selected in Device Temperature Selector.
Fan Control Mode	Read and write	It sets the fan mode. <ul style="list-style-type: none"> ● In auto mode, it includes three-level fan speed:70, 85 and 100. According to the difference between the configured sensor temperature (TEC Temperature parameter) and the actual temperature, adjustment is made every 30 seconds. If actual temperature - configured temperature > 2 degrees, fan speed will increase. Otherwise, fan speed will decrease. ● In manual mode, the fan speed is decided by value set in Fan Speed.
Fan Speed	Read and write	It sets the fan speed, and its range is from 40 to 100.
Device Command Timeout	Read only	It counts the timeout of command.

Device Control

Parameter	Read/Write	Description
Device Reset	Write only	Click Execute to reset the device.
Find Me	Read and write	Click Execute to let red indicator flash several times, and find device.
Device PJ Number	Read only	It is the device's project number.

File Access Control

The file access control allows you to export or import the device's parameters, DPC data, LUT, MPRNUC and HPRNUC, and save them in mfa format. Currently, the device supports User Set 1/2/3, DPC, LUT Luminance 1/2/3, MPRNUC, HPRNUC, and NUFFC.

Steps

1. Select a device in the device list, and click  to open the file access dialogue box.



2. Select Device Feature and click Import or Export.
3. Select a mfa file from local PC to import or select a saving path and enter file name to save and export.

	<ul style="list-style-type: none"> ● If User Set 1/2/3 is selected as device feature, you need to load the corresponding user set you selected to take effect. ● If LUT Luminance 1/2/3 is selected as device feature, and they will take effect only when you select the same parameters in LUT Selector. ● If DPC, MPRNUC, HPRNUC or NUFFC is selected as device feature, and it will take effect immediately after importing. ● Importing and exporting the device feature among the same model of devices are supported.
--	--

Save and Load User Set

The camera supports 4 sets of parameters, including 1 default set and 3 user sets. You can save parameters, load parameters and set user default as shown below.

_Save Parameters:

1. Click User Set Control, and select a user set in User Set Selector. Here we take selecting User Set 1 as an example.
2. Click Execute in User Set Save to save parameters.

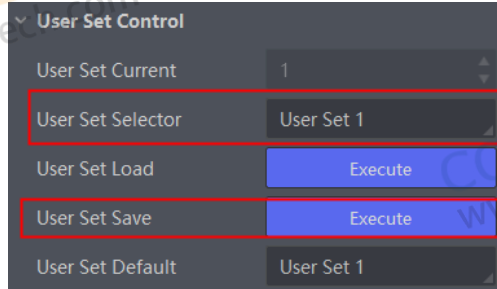

_Load Parameters:

1. Click User Set Control, and select a user set in User Set Selector. Here we take selecting User Set 1 as an example.
2. Click Execute in User Set Load to load parameters to the camera, as shown below.

i Loading parameters is available when connecting with camera, but without acquisition.

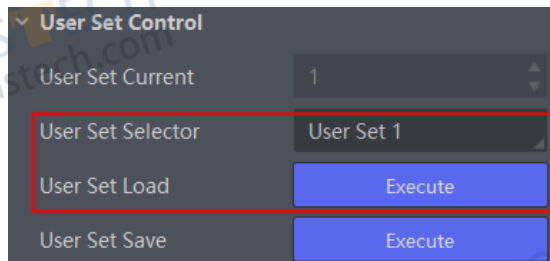

_Set User Default:

You can also set default parameter by selecting parameter from drop-down list of User Set Default.

Transport Layer Control

You can go to Transport Layer Control to view the device's payload size, tap geometry, etc.

Parameter	Read/Write	Description
Paylode Size(B)	Read only	It is the camera's load size.
Device Tap Geometry	Read and write	It is the tap configuration mode.
GenCP Version Major	Read only	It is the major version in GenCP version.
GenCP Version Minor	Read only	It is the minor version in GenCP version.
Image1StreamID	Read only	It is the ID of image 1.
Image2StreamID	Read only	It is the ID of image 2.

CoaXPress Parameters

You can go to CoaXPress attribute to set CoaXPress related parameters.

Parameter	Read/Write	Description
Device Connection ID	Read only	It is the ID of the camera's major link.
Master Host Connection ID	Read, and write is available when the camera does not acquire image	It is the camera's communication tag.
Control Packet Max Size	Read only	It is the max. value of single control data package.
Device Steam Max Size	Read, and write is available when the camera does not acquire image	It is the max. value of single image stream data package.
LinkConfiguration	Read, and write is available when the camera does not acquire image	It sets link configuration mode, link quantity and transmission bandwidth of each link.
LinkConfigurationPreferred	Read only	It is preferred link configuration mode.
ConnectionTestMode	Read and write	It is communication test mode that can check test data sent by the camera and frame grabber. It is disabled by default.
TestErrorCountSelector	Read and write	It selects link to view its test result.
TestErrorCount	Read only	It is error count of current link.
TestPacketCountTx	Read only	It is the quantity of test data sent by current link.
TestPacketCountRx	Read only	It is the quantity of test data received by current link.



You can set different link configuration modes according to actual demands.

Camera Parameter Index

Attribute	Parameter	Section
Device Control	Device Scan Type	Device Control
	Device Vendor Name	
	Device Model Name	
	Device Manufacturer Info	
	Device Version	
	Device Firmware Version	
	Device Serial Number	
	Device User ID	
	Device Revision	
	Device Manifest Size	
	Device Manifest Selector	
	Device Xml Version	
	Device Schema Version	
	Device Uptime(s)	
	Board Device Type	
	TEC Enable	
	TEC Temperature	
	Device Temperature Selector	
	Device Temperature	
	Sensor Board Temperature	
	Fan Control Mode	
	Fan Speed	
	Device Command Timeout	
Device Reset		
Find Me		
Device PJ Number		
Image Format Control	Width Max	Resolution and ROI
	Height Max	
	Region Selector	
	Width	
	Height	
	Offset X	
	Offset Y	Image Reverse
	Reverse X	
	Reverse Y	
	ADC Bit Depth	Pixel Format
	Pixel Format	
	Pixel Size	
	Test Pattern Generator Selector	Test Pattern
Test Pattern		

Camera Parameter Index

Attribute	Parameter	Section	
Image Format Control	Binning Selector	Binning	
	Binning Horizontal		
	Binning Vertical		
	Decimation Horizontal	Decimation	
	Decimation Vertical		
	FTTO Mode	FTO Mode	
Acquisition Control	Acquisition Mode	Acquisition Mode	
	Acquisition Start		
	Acquisition Stop		
	Acquisition Burst Frame Count	Trigger Related Parameters	
	Acquisition Frame Rate (Fps)	Frame Rate	
	Acquisition Frame Rate Control Enable		
	Resulting Frame Rate (Fps)		
	Overlap Mode	Overlap Mode	
	Trigger Selector	External Trigger Mode	
	Trigger Mode		
	Trigger Software		
	Trigger Source		
	Trigger Activation		
	Trigger Delay (μ s)		
	Trigger Cache Enable		
	Sensor Shutter Mode		Rolling Shutter
	Exposure Mode		Exposure Time Mode
	Exposure Time Mode		
	Exposure Time (μ s)		
	Exposure Auto		
	Auto Exposure Time Lower Limit (μ s)		
	Auto Exposure Time Upper Limit (μ s)		
	HDR Enable	HDR	
	HDR Reset		
	HDR Number		
	HDR Selector		
	HDR Shutter(μ s)		
HDR Gain			
HDR Balance Ratio R			
HDR Balance Ratio G			
HDR Balance Ratio B			
Analog Control	Preamp Gain	Analog Gain	
	Gain		
	Gain Auto		

Camera Parameter Index

Attribute	Parameter	Section
Analog Control	Auto Gain Lower Limit	Analog Gain
	Auto Gain Upper Limit	
	Digital Shift	Digital Shift
	Digital Shift Enable	
	Brightness	Brightness
	Black Level	Black Level
	Black Level Enable	
	Balance White Auto	White Balance
	AWB Color Temperature Mode	
	Balance Ratio Selector	
	Balance Ratio	Gamma
	Gamma	
	Gamma Selector	
	Gamma Enable	Sharpness
	Sharpness	
	Sharpness Enable	AOI
	Auto Function AOI Selector	
	Auto Function AOI Width	
	Auto Function AOI Height	
Auto Function AOI Offset X		
Auto Function AOI Offset Y		
Auto Function AOI Usage Intensity		
Auto Function AOI Usage White Balance		
Color Transformation Control	Color Transformation Selector	Color Transformation Control
	Color Transformation Enable	
	Color Transformation Value Selector	
	Color Transformation Value	Hue
	Hue	
	Hue Enable	Saturation
	Saturation	
Saturation Enable		
LUT Control	LUT Selector	LUT
	LUT Enable	
	LUT Index	
	LUT Value	
	LUT Value (All)	
	LUT Save	
Shading Correction	Shading Selector	Shading Correction
	Activate Shading	
	FFC Enable	

Camera Parameter Index

Attribute	Parameter	Section
Shading Correction	PRNUC Enable	Shading Correction
	NUC Enable	
	FPNC Enable	
	LSC Enable	
	LSC Table Selector	
	LSC Target Enable	
	LSC Target R	
	LSC Target G	
	LSC Target B	
	LSC Target	
	LSC Sequencer Enable	Shading Correction
	LSC Sequencer Reset	
	LSC Sequencer Number	
	LSC Sequencer Manual Enable	
	LSC Sequencer Selector	
LSC Sequencer Table		
Counter And Timer Control	Counter Selector	Counter Trigger
	Counter Event Source	
	Counter Reset Source	
	Counter Reset	
	Counter Value	
	Counter Current Value	
File Access Control	File Selector	File Access Control
	File Operation Selector	
	File Operation Excute	
	File Open Mode	
	File Operation Status	
	File Operation Result	
	File Size (B)	
Digital IO Control	Line Selector	I/O Output
	Line Mode	
	Line Inverter	
	Line Status	
	Line Status All	
	Line Source	
	Strobe Enable	
	User Output Value	
	Line Debouncer Time (μ s)	
	Strobe Line Duration (μ s)	
	Strobe Line Delay (μ s)	

Camera Parameter Index

Attribute	Parameter	Section
Digital IO Control	Strobe Line Pre Delay (μ s)	I/O Output
Transport Layer Control	Payload Size(B)	Transport Layer Control
	Device Tap Geometry	
	GenCP Version Major	
	GenCP Version Minor	
	Image1StreamID	
	Image2StreamID	
User Set Control	User Set Current	Save and Load User Set
	User Set Selector	
	User Set Load	
	User Set Save	
	User Set Default	
CoaXPress	Device Connection ID	CoaXPress
	Master Host Connection ID	
	Control Packet Max Size	
	Device Stream Max Size	
	LinkConfiguration	
	LinkConfigurationPreferred	
	ConnectionTestMode	
	TestErrorCountSelector	
	TestErrorCount	
	TestPacketCountTx	
	TestPacketCountRx	

Trouble Shooting

Trouble:

■ Frame grabber software cannot list cameras?

Possible Reason1: After powering on the camera, searching the camera via frame grabber client software too early.

Solution1: After the blue indicator lights on the camera, searching the camera via frame grabber software.

Possible Reason2: When creating new project in frame grabber software, virtual frame grabber is selected.

Solution2: When creating new project in frame grabber software, select physical frame grabber rather than virtual one. If there is no frame grabber model, check PCIe card slot.

■ Frame grabber software is stuck when listing cameras?

Possible Reason1: The camera is not connected correctly.

Solution1: Check the wiring between the camera and the frame grabber.

Possible Reason2: The frame grabber is not installed firmly.

Solution2: Reinstall the frame grabber.

■ Frame grabber software turns to the blue screen?

Possible Reason: Close frame grabber software with force during image acquisition.

Solution: Stop image acquisition first, and then close frame grabber software.

■ Frame grabber software does not update the frame rate information during live view?

Possible Reason: When the change value of frame rate in frame grabber client software is smaller than 0.5, the frame rate does not update.

Solution: When the change value of frame rate is larger than 0.5, the frame rate will update.

■ Live view image in the client software is abnormal?

Possible Reason: The camera or frame grabber exception occurs.

Go to Frame Grabber → Statistics and Tests → CRC Error Counter to check CRC Error Counter.

Solution: If CRC Error Counter is 0, frame grabber exception occurs, please contact frame grabber manufacturer.

If CRC Error Counter is not 0, camera exception occurs, please contact our technical support personnel.

CHAPTER 10 TECHNICAL SUPPORT

If you need advice about your camera or if you need assistance troubleshooting a problem with your camera, it's highly recommended to describe your issue in details and contact us via E-mail at support@contrasttech.com

It would be helpful if you can fill-in the following table and send to us before you contact our technical support team.

Camera Model:		Camera's SN:	
Describe the issue in as much detail as possible:			
If known, what's the cause of the issue?			
How often did/does the issue occur?			
How severe is the issue?			
Parameter set	Please connect the camera directly to PC and use iDatum to make note of the parameter when the issue occurred.		

Hangzhou ConrasTech Co., Ltd

No.8 Xiyuan 9th Road, West Lake District Hangzhou Zhejiang 310030 China
Tel: +86 571-89712238
www.contrasttech.com

For Research Use Only ©2023 Hangzhou ConrasTech Co., Ltd.
All rights reserved. All trademarks are the property of Hangzhou ConrasTech Co., Ltd.