

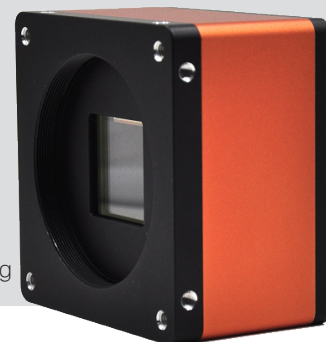

Mars50MC-30xm/xc-F

- 50MP @30 fps
- CoaXPRESS uses CXP-6, theoretical bandwidth 4 x 6.25Gbps
- Compatible with CoaXPRESS Protocol, GenICam Standard, and the third-party software based on these protocol and standard
- Support Windows operating platform
- Support PoCXP power supply and DC 24V power supply

Applied range • Printing • Textile • Railway • Logistics • Metallurgy • Food • Pharmaceutical • Material sorting



Camera	Mars50MC-30xm/xc-F
Resolution [H*V]	7920 x 6004
Sensor	CMV50000
Pixel Size [μm]	4.6 x 4.6
Frame Rate [fps]	30
Data Bit	12bit
Exposure Time	50 μs ~5s
Dynamic Range	64dB
Mono/Color	Mono / Color
Image Format	Mono: Mono8/10/12 Color: BayerBG8/10/12
Interface	CoaXPRESS
Synchronization	Via hardware trigger、software trigger or free run mode
Programmable Control [ISP]	Image resolution、RGB Gain、Exposure time、Gamma form、Image rollovers、Raw、LUT、Black level correction
Housing Size [l*w*h]	72.0 x 72.0 x 112.5 mm (720g)
Operating Temperature	-30~80 ° C (Storage), -30~50° C (Working)
Lenses Mount	F-Mount (FBL 46.5mm)
Digital I/O	6-pin Hirose interface: Configurable input and output x 3;
Power Input	PoCXP / DC 24V
Power Consumption	24V@ \approx 15W
Driver	Frame Grabber control software compliant with CoaXPRESS protocol
Operating System	Windows
Conformity	CoaXPRESS, GenICam

Spectral Response

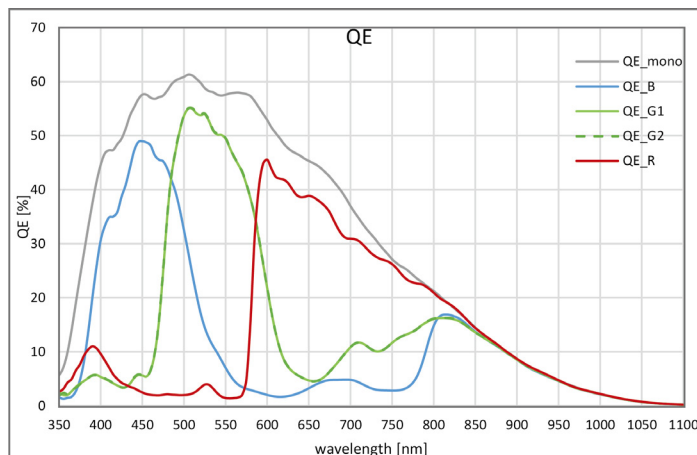

Dimensions

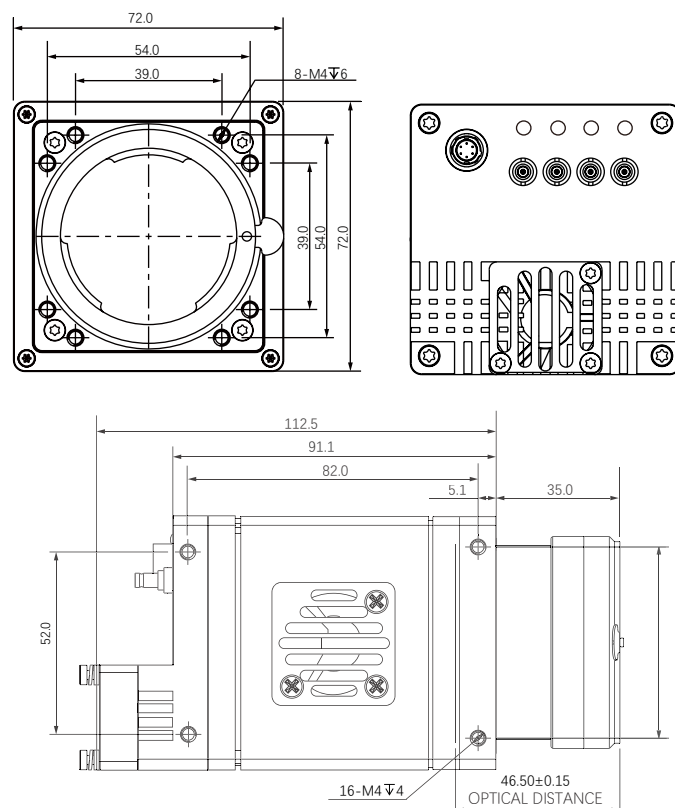

No.8, Xiyuan 9th Road West Lake District, Hangzhou 310030 China
 Tel: 86-571-89712238 Web: www.contrastech.com
 Email: market@contrastech.com

