

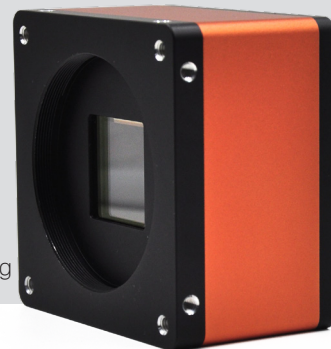

Mars25MG-150xm/xc-M42

- 25MP @150 fps
- CoaXPress uses CXP-12, theoretical bandwidth 4 x 12.5Gbps
- Compatible with CoaXPress Protocol, GenICam Standard, and the third-party software based on these protocol and standard
- Support Windows operating platform
- Support PoCXP power supply and DC 24V power supply

Applied range • Printing • Textile • Railway • Logistics • Metallurgy • Food • Pharmaceutical • Material sorting



Camera	Mars25MG-150xm/xc-M42
Resolution [H*V]	5120 x 5120
Sensor	GMAX0505
Sensor Type	1.1" CMOS
Pixel Size [μm]	2.5 x 2.5
Frame Rate [fps]	150
Data Bit	10 bit
Exposure Time	15μs~5s
Dynamic Range	63dB
Mono/Color	Mono / Color
Image Format	Mono: Mono8/10/12 Color: BayerGR8/10/12, BayerRG8/10/12, BayerGB8/10/12, BayerBG8/10/12
Interface	CoaXPress
Synchronization	Via hardware trigger, software trigger or free run mode
Programmable Control [ISP]	Image resolution, RGB Gain, Exposure time, Gamma form, Image rollovers, Raw, LUT, Black level correction
Housing Size [l*w*h]	80.0 × 80.0 × 65.3 mm (890g)
Operating Temperature	-30~80 ° C (Storage), -30~50° C (Working)
Lenses Mount	M42*1
Digital I/O	Opto-isolated input x 3, opto-isolated output x 3, RS232 x 1
Power Input	PoCXP / DC 24V
Power Consumption	24V@ ≈ 19.4W
Driver	Frame Grabber control software compliant with CoaXPress protocol
Operating System	Windows
Conformity	CoaXPress, GenICam

Spectral Response

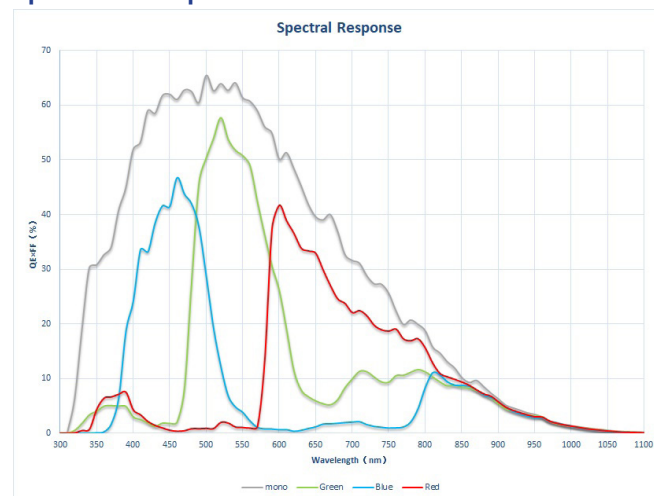

Dimensions

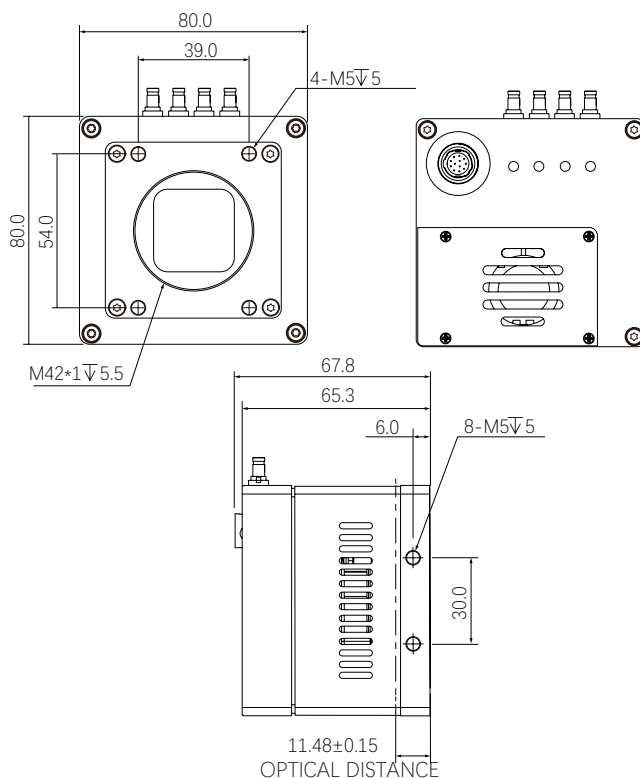

No.8, Xiyuan 9th Road West Lake District, Hangzhou 310030 China
 Tel: 86-571-89712238 Web: www.contrastech.com
 Email: market@contrastech.com

