



Mars5000S-30cm

- 5MP @30.2fps
- Compatible with Cameralink protocol and GenICam standard
- Support triggering via CameraLink frame grabber
- Support Windows operating platform
- Support DC 24V power supply



Applied range • Printing • Textile • Railway • Logistics • Metallurgy • Food • Pharmaceutical • Material sorting

Camera	Mars5000S-30cm
Resolution [H*V]	2448 x 2048
Sensor	Sony IMX264
Sensor Size	2/3"
Pixel Size [μm]	3.45 x 3.45
Frame Rate [fps]	30.2
Data Bit	10bit
Exposure Time	16 μs ~1S
Dynamic Range	70dB
Mono/Color	Mono
Image Format	Mono8/10
Interface	Cameralink
Synchronization	Via hardware trigger、software trigger or free run mode
Programmable Control [ISP]	Image resolution、Exposure time、Gamma form、Image rollovers、Raw、LUT、Black level correction
Housing Size [l*w*h]	29.0 x 29.0 x 43.8 mm (80g)
Operating Temperature	-30~80 ° C (Storage), -30~50° C (Working)
Lenses Mount	C-Mount
Digital I/O	/
Power Input	PoCL, DC 6-24V
Power Consumption	12V@2.3W
Driver	Mars Series Camera Software Suite (iCentral) or 3rd Party Cameralink Protocol Software
Operating System	Windows
Conformity	Cameralink, GenICam

Spectral Response

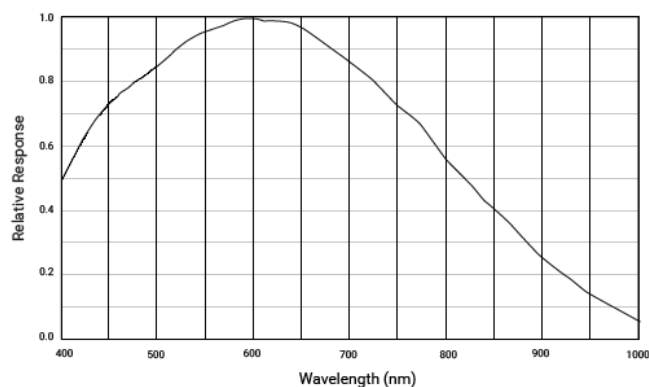

Dimensions

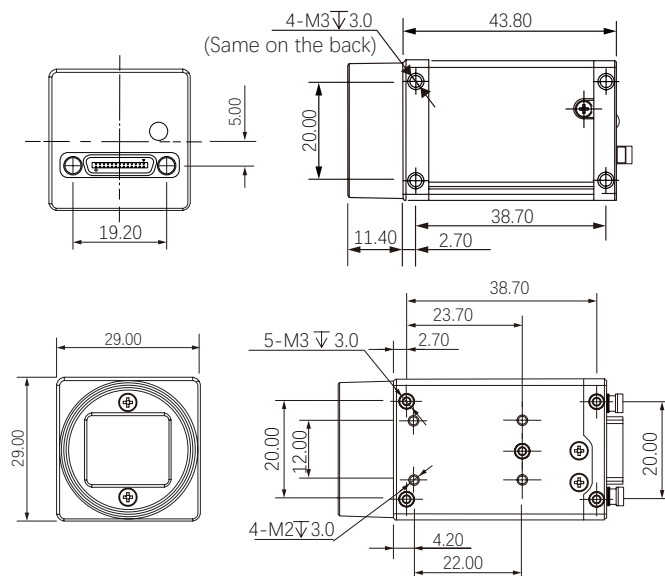

No.8, Xiyuan 9th Road West Lake District, Hangzhou 310030 China
 Tel: 86-571-89712238 Web: www.contrastech.com
 Email: market@contrastech.com

