

Shadowless Ring Illumination - High Angle -GWR Series

Features

- The lights achieve a uniform region with high luminance by using unique illumination mechanism.
- Compact design, convenient to installation.

Applications

- Inspection of defects on unfairness specular surface, food and medicine packages, the welding points of electronic components, etc..



Examples of Shadowless GWR Light Images



Lights: GWR150W

Imaging of keyboard and inner buttons

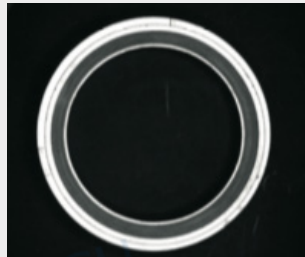

Lights: GWR150W

Imaging of cambered surface

Illumination Structure

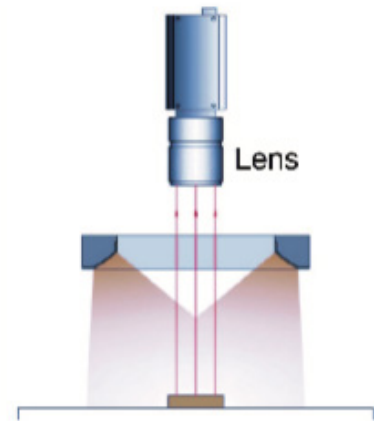

Dimension

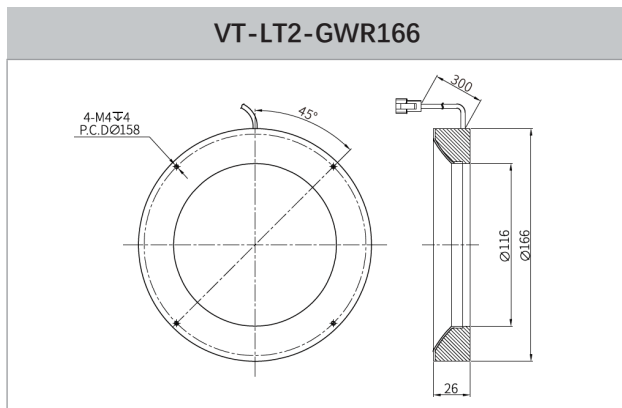

Explanation of Model Code

VT-LT2-GWR	60	(W/B/R)
Series	Outer Diameter	Color

Model No.	Electrical specifications (GREEN / NIR / UV Accept custom)			Dimensions		
	Supply Voltage (v)	Power cons. (w)	Power cons. (w)	Outer diam. (mm)	Inner diam. (mm)	Height (mm)
VT-LT2-GWR166	24	13.2	19.2	166	116	26