



LEO 12MS-70cc

- 12MP resolution @68.1 fps
- Adopts CameraLink interface to transmit data
- Supports four configuration modes: Base,Medium,Full and 80-bit
- Compatible with CameraLink Vision Protocol, GenICam Standard, and the third-party software based on these protocol and standard
- Support Windows



Applied range • Defect Detection • Surface Patch Detection • Visual Positioning • Size Measuring • QR Code Reading • VR/AR • Logistics

Camera	LEO 12MS-70cc
Resolution [H*V]	3840 × 3000
Sensor	Sony IMX253
Sensor Size	1.1"
Sensor Technology	Global, CMOS
Pixel Pize [μm]	3.45 × 3.45
Rrame Rate [fps]	68.1 fps
Configuration mode	Base / Medium / Full / 80-bit
Taps	1 / 2 / 4 / 8 / 10 Taps
Data Bit	8bit / 10bit / 12bit
Exposure Time	1μs~10s
Dynamic Range	>71dB
Mono/Color	Color
Image Format	Bayer RG 8/10/12, RGB 8
Interface	Camera Link (SDR port)
Synchronization	Via hardware trigger、software trigger or free run mode
Programmable Control [ISP]	Image resolution、RGB gain、Exposure time、Gamma form、Image rollovers、Raw、LUT、Black level correction
Housing Size [l*w*h]	29 × 44 × 59 mm (100g)
Operating Temperature	-30~70 ° C (Storage), 0~50° C (Working)
Lenses Mount	C-Mount
Digital I/O	Opto-isolated input x 1, opto-isolated output x 1, and bi-directional non-isolated I/O x 1
Power Input	DC 9-24V
Power Consumption	12V @4.68W
Driver	LEO Series Camera Software Suite (iDatum) or Frame Grabber Software Compliant With GenICam Protocol
Operating System	Windows
Conformity	Camera Link,GenICam

Spectral Response

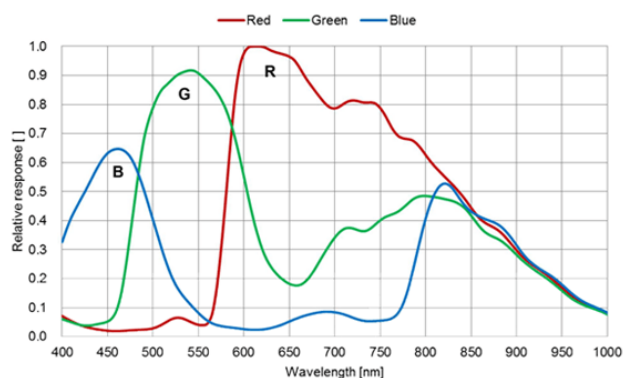

Dimensions

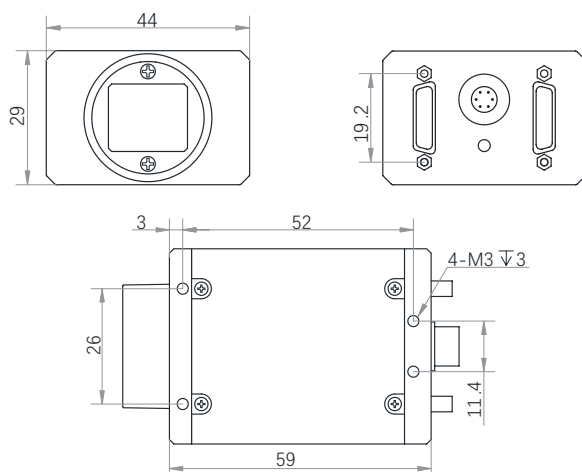

No.8, Xiyuan 9th Road West Lake District, Hangzhou 310030 China
 Tel: 86-571-89712238 Web: www.contrastech.com
 Email: market@contrastech.com