

BTL SERIES

NEW



PRODUCT FEATURES

1. Optimized for 1/2.5"~1.1" C-Mount cameras;
2. Largest FOV from 26mm upto 300mm;
3. Excellent resolution for high pixel cameras;
4. Low distortion, good telecentricity, big aperture and big depth of field for high end application.

NAMING RULES

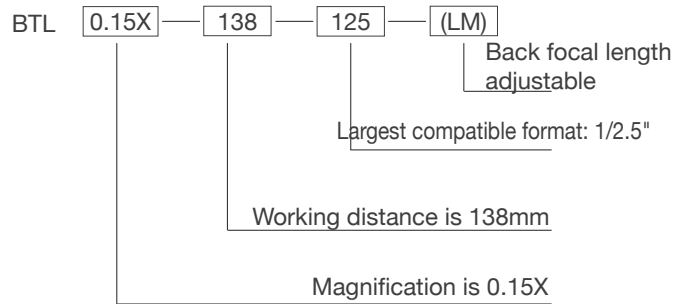

OVERVIEW

BTL Series Magnification Crosstab

Sensor Size FOV (mm) Mag X	1/2.5" BTL-125	1/2" BTL-12	1/1.8" BTL-118	2/3" BTL-23	1" BTL-H1	1.1" BTL-H1.1	4/3" BTL-H2	1.75" BTL-175	2" BTL-21	39mm BTL-71M	44mm BTL-FF	59mm BTL-16K	WD(mm)
26	0.277	0.308	0.346	0.438	0.638	0.708	0.923	1.115	/	/	/	/	73
36	0.2	0.222	0.25	0.317	0.46	0.511	0.67	0.806	0.917	1.083	/	/	110
42	0.171	0.19	0.214	0.271	0.395	0.438	0.571	0.69	0.786	0.929	1.048	/	118
48	0.15	0.167	0.188	0.238	0.346	0.383	0.5	0.604	0.688	0.813	0.92	/	128
56	0.129	0.143	0.161	0.204	0.296	0.329	0.429	0.518	0.589	0.696	0.785	/	138
64	0.113	0.125	0.14	0.178	0.258	0.287	0.375	0.453	0.516	0.609	0.688	/	189
72	0.1	0.111	0.125	0.158	0.231	0.256	0.333	0.403	0.458	0.542	0.611	/	178
80	0.09	0.1	0.113	0.142	0.206	0.23	0.3	0.363	0.41	0.488	0.55	/	228
90	0.08	0.089	0.1	0.127	0.184	0.204	0.267	0.322	0.367	0.433	0.489	0.656	208
100	0.072	0.08	0.09	0.114	0.166	0.184	0.24	0.29	0.33	0.39	0.44	/	258
120	0.06	0.067	0.075	0.095	0.138	0.153	0.2	0.242	0.275	0.325	0.367	/	280
150	0.048	0.053	0.06	0.076	0.11	0.123	0.16	0.193	0.22	0.26	0.293	0.393	300
190	0.038	0.042	0.047	0.06	0.087	0.097	0.126	0.153	0.174	0.205	0.23	0.311	330
240	0.03	0.033	0.038	0.048	0.069	0.077	0.1	0.121	0.138	0.163	0.183	0.246	410
300	0.024	0.027	0.03	0.038	0.055	0.061	0.08	0.097	0.11	0.13	0.147	0.197	465
Mount	C	C	C	C	C	C	C/F	F	F	F	F	M72	

BTL-H2 SERIES



Model No. ¹	Optical specs										Mechanical specs		
	FOV (Φmm)	Mag. (x)	WD (mm) ²	Max. Sesnor Size (Φmm)	F/#	MTF30 (lp/mm)	DOF (mm) ³	Distortion (% max) ⁴	Telecentricity (° max) ⁵	I/O (mm) ⁶	Length (mm)	Mount	Weight (kg)
BTL-0.923X-73-H2(LM)	26	0.923	73±1	24(4/3")	12.5	>65	±0.9@F20	<0.1	<0.1	264±1	144.0	C/F	0.7
BTL-0.67X-110-H2(LM)	36	0.670	110±2	24(4/3")	11.3	>70	±1.7@F20	<0.1	<0.1	321±2	164.0	C/F	0.8
BTL-0.571X-118-H2(LM)	42	0.571	118±3	24(4/3")	9.4	>90	±2.4@F20	<0.1	<0.1	314±3	149.5	C/F	0.8
BTL-0.5X-128-H2(LM)	48	0.500	128±3	24(4/3")	9.4	>85	±3.2@F20	<0.1	<0.1	338±3	163.0	C/F	0.8
BTL-0.5X-138-H2(LM)	48	0.500	138±3	24(4/3")	14.1	>60	±3.2@F20	<0.1	<0.1	333±3	148.0	C/F	0.8
BTL-0.429X-138-H2(LM)	56	0.429	138±3	24(4/3")	8.1	>110	±3.4@F16	<0.1	<0.1	370±3	185.5	C/F	1.1
BTL-0.375X-189-H2(LM)	64	0.375	189±3	24(4/3")	14.1	>60	±5.6@F20	<0.1	<0.1	410±3	174.0	C/F	1.2
BTL-0.333X-178-H2(LM)	72	0.333	178±3	24(4/3")	7.5	>120	±5.7@F16	<0.1	<0.1	443±3	218.0	C/F	1.4
BTL-0.3X-228-H2(LM)	80	0.3000	228±4	24(4/3")	14.1	>60	±8.8@F20	<0.1	<0.1	482±4	207.9	C/F	1.9
BTL-0.267X-208-H2(LM)	90	0.267	208±3	24(4/3")	7.5	>120	±9@F16	<0.1	<0.1	498±3	243.0	C/F	2.1
BTL-0.24X-258-H2(LM)	100	0.240	258±4	24(4/3")	9.4	>95	±13.8@F20	<0.1	<0.1	571±4	266.4	C/F	3.4
BTL-0.2X-280-H2(LM)	120	0.200	280±5	24(4/3")	8.1	>110	±16@F16	<0.1	<0.1	633±5	306.7	C/F	4.6
BTL-0.16X-300-H2(LM)	150	0.16	300±5	24(4/3")	8.1	>115	±25@F16	<0.1	<0.1	697±5	350.0	C/F	6.1
BTL-0.126X-330-H2(LM)	190	0.126	330±5	24(4/3")	7.5	>120	±40.3@F16	<0.1	<0.1	816±5	439.3	C/F	11.4
BTL-0.1X-410-H2(LM)	240	0.100	410±6	24(4/3")	7.5	>115	±80@F20	<0.1	<0.1	1047±6	590.3	C/F	25.9
BTL-0.08X-465-H2(LM)	300	0.080	465±6	24(4/3")	7.5	>115	±100@F16	<0.1	<0.1	1171±6	659.0	C/F	46.9

1. The back focal length of model with (LM) is adjustable.

2. Working distance: distance between the front end of the mechanics and the object. Set this distance within the nominal value for maximum resolution and minimum distortion.

3. At the borders of the field depth the image can be still used for measurement.

4. Percent deviation of the real image compared to an ideal, undistorted image: maximum (guaranteed) values are listed.

5. Maximum slope of chief rays inside the lens: when converted to milliradians, it gives the maximum measurement error for any millimeter of object displacement. Maximum (guaranteed) values are listed.

6. I/O: distance between the sensor(image) and the object.

BTL-0.923X-73-H2(LM)

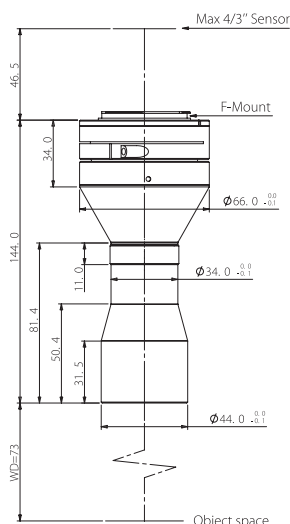

FOV(Φmm)	26
Mag.(x)	0.923
WD(mm)	73±1
Max Sensor Size(Φmm)	24(4/3")
F/#	12.5
MTF30(lp/mm)	>65
DoF(mm)	±0.9@F20
Distortion(% max)	<0.1
Telecentricity(° max)	<0.1
I/O(mm)	264±1
Length(mm)	144.0
Mount	C/F-Mount
Weight(kg)	0.7

Field of View(mm xmm)	
1/2.5" 9P001/31(5.7x4.28)	19.6x14.7
4/3" CMV8000(18.48x13.73)	20.0x14.9

BTL-0.67X-110-H2(LM)

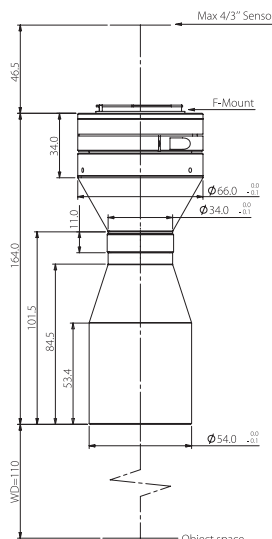

FOV(Φmm)	36
Mag.(x)	0.670
WD(mm)	110±2
Max Sensor Size(Φmm)	24(4/3")
F/#	11.3
MTF30(lp/mm)	>70
DoF(mm)	±1.7@F20
Distortion(% max)	<0.1
Telecentricity(° max)	<0.1
I/O(mm)	321±2
Length(mm)	164.0
Mount	C/F-Mount
Weight(kg)	0.8

Field of View(mm xmm)	
1/2.5" 9P001/31(5.7x4.28)	27.1x20.3
4/3" CMV8000(18.48x13.73)	27.6x20.5

BTL-0.571X-118-H2(LM)

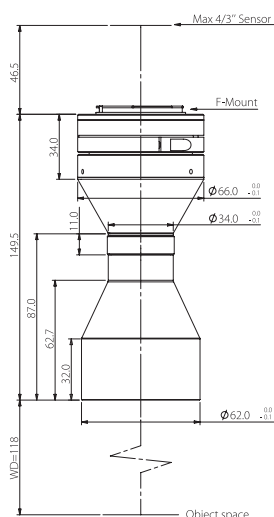

FOV(Φmm)	42
Mag.(x)	0.171
WD(mm)	118±3
Max Sensor Size(Φmm)	24(4/3")
F/#	4.2
MTF30(lp/mm)	>200
DoF(mm)	±15.0@F11
Distortion(% max)	<0.1
Telecentricity(° max)	<0.1
I/O(mm)	245±3
Length(mm)	108.9
Mount	C/F-Mount
Weight(kg)	0.4

Field of View(mm xmm)	
4/3" KAI-08050(18.13x13.6)	33.3x25.0
4/3" CMV8000(18.48x13.73)	32.4x24.1

BTL-0.5X-128-H2(LM)

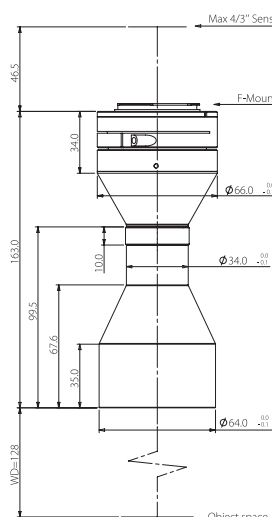

FOV(Φmm)	48
Mag.(x)	0.150
WD(mm)	128±3
Max Sensor Size(Φmm)	24(4/3")
F/#	4.2
MTF30(lp/mm)	>190
DoF(mm)	±19.5@F11
Distortion(% max)	<0.1
Telecentricity(° max)	<0.1
I/O(mm)	268±3
Length(mm)	122.4
Mount	C/F-Mount
Weight(kg)	0.4

Field of View(mm xmm)	
4/3" KAI-08050(18.13x13.6)	38.0x28.5
4/3" CMV8000(18.48x13.73)	37.0x27.5

BTL-0.5X-138-H2(LM)

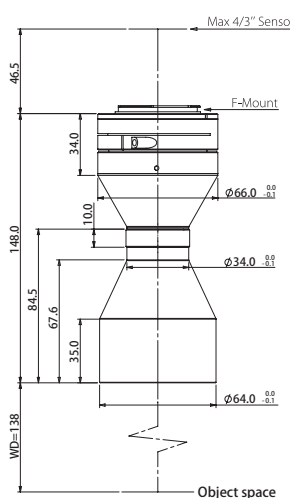

FOV(Φmm)	48
Mag.(x)	0.150
WD(mm)	138±3
Max Sensor Size(Φmm)	24(4/3")
F/#	4.2
MTF30(lp/mm)	>190
DoF(mm)	±19.5@F11
Distortion(% max)	<0.1
Telecentricity(° max)	<0.1
I/O(mm)	263±3
Length(mm)	107.5
Mount	C/F-Mount
Weight(kg)	0.4

Field of View(mm xmm)	
4/3" KAI-08050(18.13x13.6)	38.0x28.5
4/3" CMV8000(18.48x13.73)	37.0x27.5

BTL-0.429X-138-H2(LM)

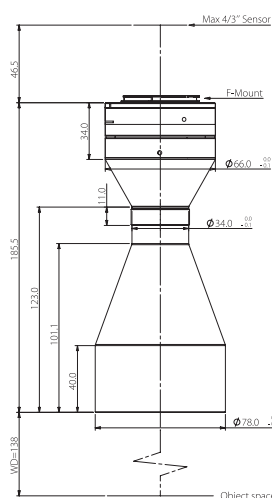

FOV(Φmm)	56
Mag.(x)	0.129
WD(mm)	138±3
Max Sensor Size(Φmm)	24(4/3")
F/#	4.2
MTF30(lp/mm)	>200
DoF(mm)	±26.4@F11
Distortion(% max)	<0.1
Telecentricity(° max)	<0.1
I/O(mm)	301±3
Length(mm)	145.0
Mount	C/F-Mount
Weight(kg)	0.7

Field of View(mm xmm)	
4/3" KAI-08050(18.13x13.6)	44.2x33.2
4/3" CMV8000(18.48x13.73)	43.1x32.0

BTL-0.375X-189-H2(LM)

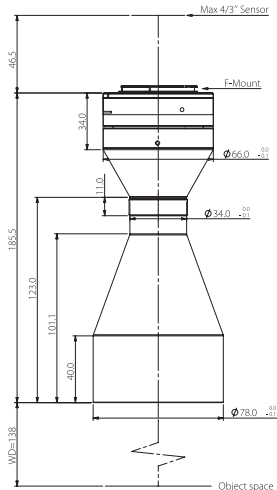

FOV(Φmm)	64
Mag.(x)	0.375
WD(mm)	189±3
Max Sensor Size(Φmm)	24(4/3")
F/#	14.1
MTF30(lp/mm)	>60
DoF(mm)	±5.6@F20
Distortion(% max)	<0.1
Telecentricity(° max)	<0.1
I/O(mm)	410±3
Length(mm)	174.0
Mount	C/F-Mount
Weight(kg)	1.2

Field of View(mm xmm)	
4/3" KAI-08050(18.13x13.6)	48.4x36.3
4/3" CMV8000(18.48x13.73)	49.3x36.6

BTL-0.333X-178-H2(LM)

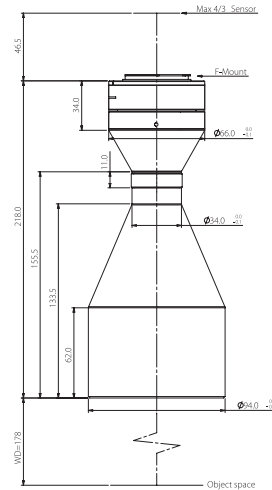

FOV(Φmm)	72
Mag.(x)	0.333
WD(mm)	178±3
Max Sensor Size(Φmm)	24(4/3")
F/#	7.5
MTF30(lp/mm)	>120
DoF(mm)	±5.7@F16
Distortion(% max)	<0.1
Telecentricity(° max)	<0.1
I/O(mm)	443±3
Length(mm)	218.0
Mount	C/F-Mount
Weight(kg)	1.4

Field of View(mm xmm)	
4/3" KAI-08050(18.13x13.6)	54.4x40.8
4/3" CMV8000(18.48x13.73)	55.5x41.2

BTL-0.3X-228-H2(LM)

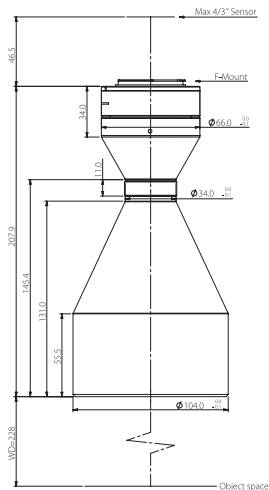

FOV(Φmm)	80
Mag.(x)	0.300
WD(mm)	228±4
Max Sensor Size(Φmm)	24(4/3")
F/#	14.1
MTF30(lp/mm)	>60
DoF(mm)	±8.8@F20
Distortion(% max)	<0.1
Telecentricity(° max)	<0.1
I/O(mm)	482±4
Length(mm)	207.9
Mount	C/F-Mount
Weight(kg)	1.9

Field of View(mm xmm)	
4/3" KAI-08050(18.13x13.6)	60.4x45.3
4/3" CMV8000(18.48x13.73)	61.6x45.8

BTL-0.267X-208-H2(LM)

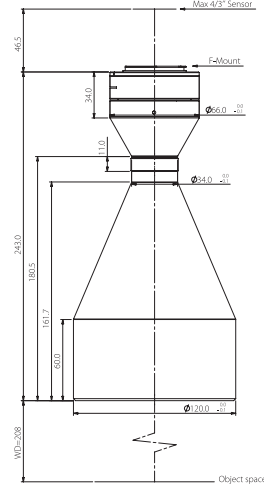

FOV(Φmm)	90
Mag.(x)	0.267
WD(mm)	208±3
Max Sensor Size(Φmm)	24(4/3")
F/#	7.5
MTF30(lp/mm)	>120
DoF(mm)	±9@F16
Distortion(% max)	<0.1
Telecentricity(° max)	<0.1
I/O(mm)	498±3
Length(mm)	243.0
Mount	C/F-Mount
Weight(kg)	2.1

Field of View(mm xmm)	
4/3" KAI-08050(18.13x13.6)	67.9x50.9
4/3" CMV8000(18.48x13.73)	69.2x51.4

BTL-0.24X-258-H2(LM)

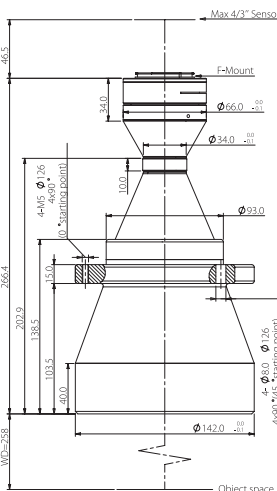

FOV(Φmm)	100
Mag.(x)	0.240
WD(mm)	258±4
Max Sensor Size(Φmm)	24(4/3")
F/#	9.4
MTF30(lp/mm)	>95
DoF(mm)	±13.8@F20
Distortion(% max)	<0.1
Telecentricity(° max)	<0.1
I/O(mm)	571±4
Length(mm)	266.4
Mount	C/F-Mount
Weight(kg)	3.4

Field of View(mm xmm)	
4/3" KAI-08050(18.13x13.6)	75.5x56.7
4/3" CMV8000(18.48x13.73)	77.0x57.2

BTL-0.2X-280-H2(LM)

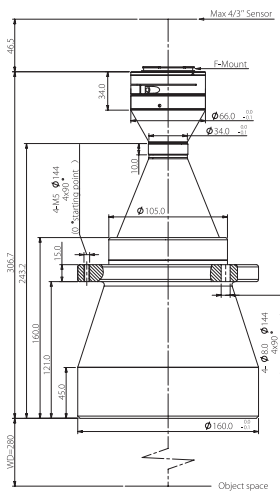

FOV(Φmm)	120
Mag.(x)	0.200
WD(mm)	280±5
Max Sensor Size(Φmm)	24(4/3")
F/#	8.1
MTF30(lp/mm)	>110
DoF(mm)	±16.0@F16
Distortion(% max)	<0.1
Telecentricity(° max)	<0.1
I/O(mm)	633±5
Length(mm)	306.7
Mount	C/F-Mount
Weight(kg)	4.6

Field of View(mm xmm)	
4/3" KAI-08050(18.13x13.6)	90.7x68.0
4/3" CMV8000(18.48x13.73)	92.4x68.7

BTL-0.16X-300-H2(LM)

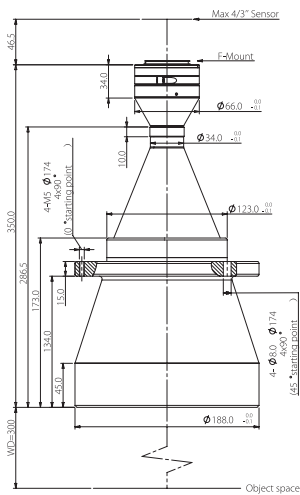

FOV(Φmm)	150
Mag.(x)	0.160
WD(mm)	300±5
Max Sensor Size(Φmm)	24(4/3")
F/#	8.1
MTF30(lp/mm)	>115
DoF(mm)	±25.0@F16
Distortion(% max)	<0.1
Telecentricity(° max)	<0.1
I/O(mm)	697±5
Length(mm)	350.0
Mount	C/F-Mount
Weight(kg)	6.1

Field of View(mm x mm)	
4/3" KAI-08050(18.13x13.6)	113.3x85.0
4/3" CMV8000(18.48x13.73)	115.5x85.8

BTL-0.126X-330-H2(LM)

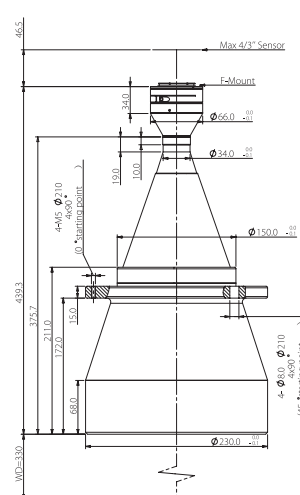

FOV(Φmm)	190
Mag.(x)	0.126
WD(mm)	330±5
Max Sensor Size(Φmm)	24(4/3")
F/#	7.5
MTF30(lp/mm)	>120
DoF(mm)	±40.3@F16
Distortion(% max)	<0.1
Telecentricity(° max)	<0.1
I/O(mm)	816±5
Length(mm)	439.3
Mount	C/F-Mount
Weight(kg)	11.4

Field of View(mm x mm)	
4/3" KAI-08050(18.13x13.6)	143.9x107.9
4/3" CMV8000(18.48x13.73)	146.7x109.0

BTL-0.1X-410-H2(LM)

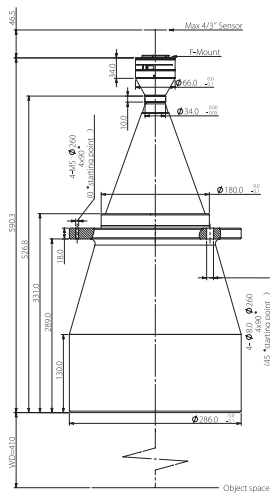

FOV(Φmm)	240
Mag.(x)	0.100
WD(mm)	410±6
Max Sensor Size(Φmm)	24(4/3")
F/#	7.5
MTF30(lp/mm)	>115
DoF(mm)	±80.0@F20
Distortion(% max)	<0.1
Telecentricity(° max)	<0.1
I/O(mm)	1047±6
Length(mm)	590.3
Mount	C/F-Mount
Weight(kg)	25.9

Field of View(mm x mm)	
4/3" KAI-08050(18.13x13.6)	181.3x136.0
4/3" CMV8000(18.48x13.73)	184.8x137.3

BTL-0.08X-465-H2(LM)

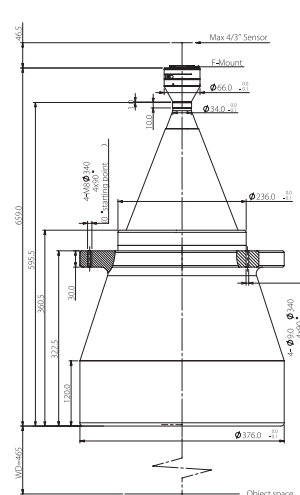

FOV(Φmm)	300
Mag.(x)	0.080
WD(mm)	465±6
Max Sensor Size(Φmm)	24(4/3")
F/#	7.5
MTF30(lp/mm)	>115
DoF(mm)	±100@F16
Distortion(% max)	<0.1
Telecentricity(° max)	<0.1
I/O(mm)	1171±6
Length(mm)	659.0
Mount	C/F-Mount
Weight(kg)	46.9

Field of View(mm x mm)	
4/3" KAI-08050(18.13x13.6)	226.6x170.0
4/3" CMV8000(18.48x13.73)	231.0x171.6