

# BTL SERIES

**NEW**



## PRODUCT FEATURES

1. Optimized for 1/2.5"~1.1" C-Mount cameras;
2. Largest FOV from 26mm upto 300mm;
3. Excellent resolution for high pixel cameras;
4. Low distortion, good telecentricity, big aperture and big depth of field for high end application.

## NAMING RULES

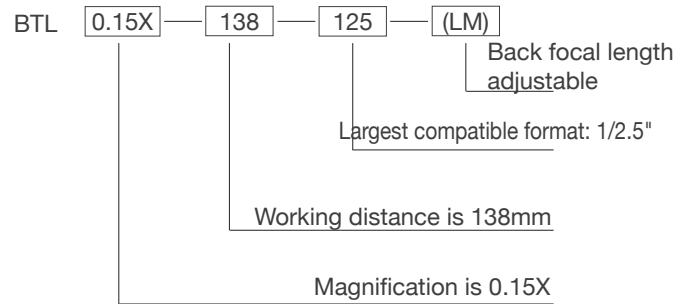

## OVERVIEW

BTL Series Magnification Crosstab

Sensor Size FOV (mm) Mag X	1/2.5" BTL-125	1/2" BTL-12	1/1.8" BTL-118	2/3" BTL-23	1" BTL-H1	1.1" BTL-H1.1	4/3" BTL-H2	1.75" BTL-175	2" BTL-21	39mm BTL-71M	44mm BTL-FF	59mm BTL-16K	WD(mm)
26	0.277	0.308	0.346	0.438	0.638	0.708	0.923	1.115	/	/	/	/	73
36	0.2	0.222	0.25	0.317	0.46	0.511	0.67	0.806	0.917	1.083	/	/	110
42	0.171	0.19	0.214	0.271	0.395	0.438	0.571	0.69	0.786	0.929	1.048	/	118
48	0.15	0.167	0.188	0.238	0.346	0.383	0.5	0.604	0.688	0.813	0.92	/	128
56	0.129	0.143	0.161	0.204	0.296	0.329	0.429	0.518	0.589	0.696	0.785	/	138
64	0.113	0.125	0.14	0.178	0.258	0.287	0.375	0.453	0.516	0.609	0.688	/	189
72	0.1	0.111	0.125	0.158	0.231	0.256	0.333	0.403	0.458	0.542	0.611	/	178
80	0.09	0.1	0.113	0.142	0.206	0.23	0.3	0.363	0.41	0.488	0.55	/	228
90	0.08	0.089	0.1	0.127	0.184	0.204	0.267	0.322	0.367	0.433	0.489	0.656	208
100	0.072	0.08	0.09	0.114	0.166	0.184	0.24	0.29	0.33	0.39	0.44	/	258
120	0.06	0.067	0.075	0.095	0.138	0.153	0.2	0.242	0.275	0.325	0.367	/	280
150	0.048	0.053	0.06	0.076	0.11	0.123	0.16	0.193	0.22	0.26	0.293	0.393	300
190	0.038	0.042	0.047	0.06	0.087	0.097	0.126	0.153	0.174	0.205	0.23	0.311	330
240	0.03	0.033	0.038	0.048	0.069	0.077	0.1	0.121	0.138	0.163	0.183	0.246	410
300	0.024	0.027	0.03	0.038	0.055	0.061	0.08	0.097	0.11	0.13	0.147	0.197	465
Mount	C	C	C	C	C	C	C/F	F	F	F	F	M72	

# BTL-175 SERIES

1.75"



Model No. <sup>1</sup>	Optical specs										Mechanical specs		
	FOV (Φmm)	Mag. (x)	WD (mm) <sup>2</sup>	Max. Sensor Size (Φmm)	F/#	MTF30 (lp/mm)	DOF (mm) <sup>3</sup>	Distortion (% max) <sup>4</sup>	Telecentricity (° max) <sup>5</sup>	I/O (mm) <sup>6</sup>	Length (mm)	Mount	Weight (kg)
BTL-1.115X-73-175(LM)	26	1.115	73±1	29(1.75")	15	>50	±0.6@F20	<0.1	<0.1	274±1	154.7	F or other	0.7
BTL-0.806X-110-175(LM)	36	0.806	110±2	29(1.75")	13.5	>60	±1.2@F20	<0.1	<0.1	331±2	174.8	F or other	0.8
BTL-0.69X-118-175(LM)	42	0.69	118±3	29(1.75")	11.4	>70	±1.6@F20	<0.1	<0.1	325±3	160.3	F or other	0.8
BTL-0.604X-128-175(LM)	48	0.604	128±3	29(1.75")	11.3	>70	±2.2@F20	<0.1	<0.1	348±3	173.8	F or other	0.9
BTL-0.604X-138-175(LM)	48	0.604	138±3	29(1.75")	17.1	>50	±2.2@F20	<0.1	<0.1	343±3	158.8	F or other	0.9
BTL-0.518X-138-175(LM)	56	0.518	138±3	29(1.75")	9.7	>85	±3.0@F20	<0.1	<0.1	381±3	196.3	F or other	1.1
BTL-0.453X-189-175(LM)	64	0.453	189±3	29(1.75")	17.1	>48	±3.8@F20	<0.1	<0.1	420±3	184.8	F or other	1.2
BTL-0.403X-178-175(LM)	72	0.403	178±3	29(1.75")	8.5	>105	±3.9@F16	<0.1	<0.1	453±3	228.8	F or other	1.5
BTL-0.363X-228-175(LM)	80	0.363	228±4	29(1.75")	17.1	>50	±6.0@F20	<0.1	<0.1	493±4	218.7	F or other	1.9
BTL-0.322X-208-175(LM)	90	0.322	208±3	29(1.75")	8.5	>100	±6.1@F16	<0.1	<0.1	508±3	253.8	F or other	2.1
BTL-0.29X-258-175(LM)	100	0.29	258±4	29(1.75")	11.3	>70	±9.5@F20	<0.1	<0.1	582±4	277.1	F or other	3.5
BTL-0.242X-280-175(LM)	120	0.242	280±5	29(1.75")	9.7	>90	±13.6@F20	<0.1	<0.1	644±5	317.5	F or other	4.6
BTL-0.193X-300-175(LM)	150	0.193	300±5	29(1.75")	9.7	>90	±21.5@F20	<0.1	<0.1	707±5	360.7	F or other	6.1
BTL-0.153X-330-175(LM)	190	0.153	330±5	29(1.75")	6.8	>130	±27.3@F16	<0.1	<0.1	827±5	450	F or other	11.4
BTL-0.121X-410-175(LM)	240	0.121	410±6	29(1.75")	6.8	>130	±43.7@F16	<0.1	<0.1	1058±6	601.1	F or other	25.9
BTL-0.097X-465-175(LM)	300	0.097	465±6	29(1.75")	8.5	>105	±68@F16	<0.1	<0.1	1181±6	669.8	F or other	47.0

1. The back focal length of model with (LM) is adjustable.

2. Working distance: distance between the front end of the mechanics and the object. Set this distance within the nominal value for maximum resolution and minimum distortion.

3. At the borders of the field depth the image can be still used for measurement.

4. Percent deviation of the real image compared to an ideal, undistorted image: maximum (guaranteed) values are listed.

5. Maximum slope of chief rays inside the lens: when converted to milliradians, it gives the maximum measurement error for any millimeter of object displacement. Maximum (guaranteed) values are listed.

6. I/O: distance between the sensor(image) and the object.

### BTL-1.115X-73-175(LM)

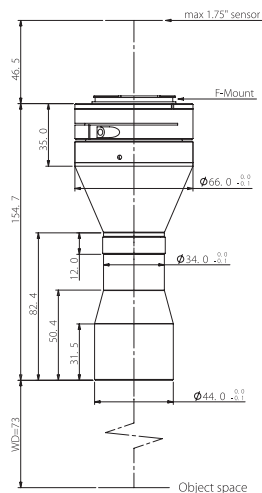

FOV(Φmm)	26
Mag.(x)	1.115
WD(mm)	73±1
Max Sensor Size(Φmm)	29(1.75")
F/#	15.0
MTF30(lp/mm)	>50
DoF(mm)	±0.6@F20
Distortion(% max)	<0.1
Telecentricity(° max)	<0.1
I/O(mm)	274±1
Length(mm)	154.7
Mount	F-Mount/Other
Weight(kg)	0.7

Field of View(mm x mm)	
1.75"CMV12000(22.53x16.90)	20.2x15.2
1.75"PYTHON16k(18.43x18.43)	16.5x16.5
1.75"LineScan-2k/4k/8k(28.8)	25.8

### BTL-0.806X-110-175(LM)

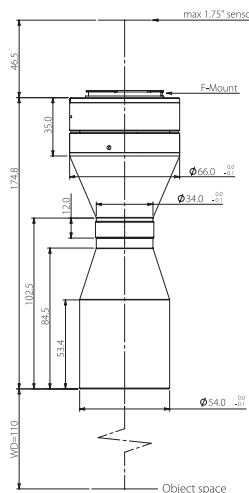

FOV(Φmm)	36
Mag.(x)	0.806
WD(mm)	110±2
Max Sensor Size(Φmm)	29(1.75")
F/#	13.5
MTF30(lp/mm)	>60
DoF(mm)	±1.2@F20
Distortion(% max)	<0.1
Telecentricity(° max)	<0.1
I/O(mm)	331±2
Length(mm)	174.8
Mount	F-Mount/Other
Weight(kg)	0.8

Field of View(mm x mm)	
1.75"CMV12000(22.53x16.90)	28.0x21.0
1.75"PYTHON16k(18.43x18.43)	22.9x22.9
1.75"LineScan-2k/4k/8k(28.8)	35.7

### BTL-0.69X-118-175(LM)

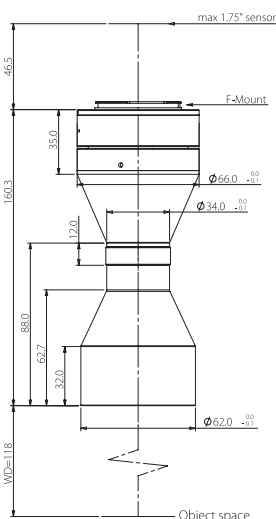

FOV(Φmm)	42
Mag.(x)	0.690
WD(mm)	118±3
Max Sensor Size(Φmm)	29(1.75")
F/#	11.4
MTF30(lp/mm)	>70
DoF(mm)	±1.6@F20
Distortion(% max)	<0.1
Telecentricity(° max)	<0.1
I/O(mm)	325±3
Length(mm)	160.3
Mount	F-Mount/Other
Weight(kg)	0.8

Field of View(mm x mm)	
1.75"CMV12000(22.53x16.90)	32.7x24.5
1.75"PYTHON16k(18.43x18.43)	26.7x26.7
1.75"LineScan-2k/4k/8k(28.8)	41.7

### BTL-0.604X-128-175(LM)

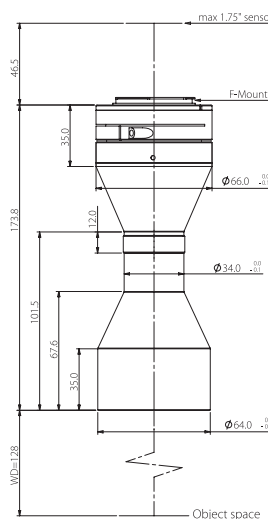

FOV(Φmm)	48
Mag.(x)	0.604
WD(mm)	128±3
Max Sensor Size(Φmm)	29(1.75")
F/#	11.3
MTF30(lp/mm)	>70
DoF(mm)	±2.2@F20
Distortion(% max)	<0.1
Telecentricity(° max)	<0.1
I/O(mm)	348±3
Length(mm)	173.8
Mount	F-Mount/Other
Weight(kg)	0.9

Field of View(mm x mm)	
1.75"CMV12000(22.53x16.90)	37.3x28.0
1.75"PYTHON16k(18.43x18.43)	30.5x30.5
1.75"LineScan-2k/4k/8k(28.8)	47.7

### BTL-0.604X-138-175(LM)

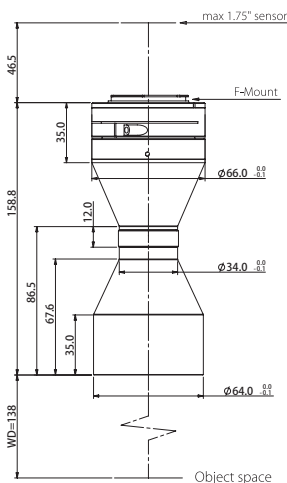

FOV(Φmm)	48
Mag.(x)	0.604
WD(mm)	138±3
Max Sensor Size(Φmm)	29(1.75")
F/#	17.1
MTF30(lp/mm)	>50
DoF(mm)	±2.2@F20
Distortion(% max)	<0.1
Telecentricity(° max)	<0.1
I/O(mm)	343±3
Length(mm)	158.8
Mount	F-Mount/Other
Weight(kg)	0.9

Field of View(mm x mm)	
1.75"CMV12000(22.53x16.90)	37.3x28.0
1.75"PYTHON16k(18.43x18.43)	30.5x30.5
1.75"LineScan-2k/4k/8k(28.8)	47.7

### BTL-0.518X-138-175(LM)

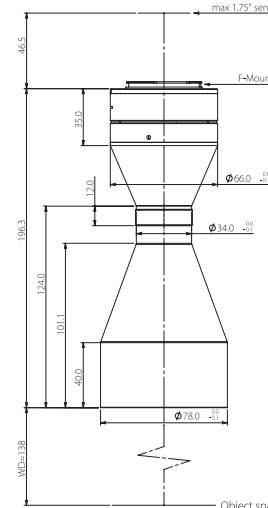

FOV(Φmm)	56
Mag.(x)	0.518
WD(mm)	138±3
Max Sensor Size(Φmm)	29(1.75")
F/#	9.7
MTF30(lp/mm)	>85
DoF(mm)	±3.0@F20
Distortion(% max)	<0.1
Telecentricity(° max)	<0.1
I/O(mm)	381±3
Length(mm)	196.3
Mount	F-Mount/Other
Weight(kg)	1.1

Field of View(mm x mm)	
1.75"CMV12000(22.53x16.90)	43.5x32.6
1.75"PYTHON16k(18.43x18.43)	35.6x35.6
1.75"LineScan-2k/4k/8k(28.8)	55.6

## BTL-0.453X-189-175(LM)

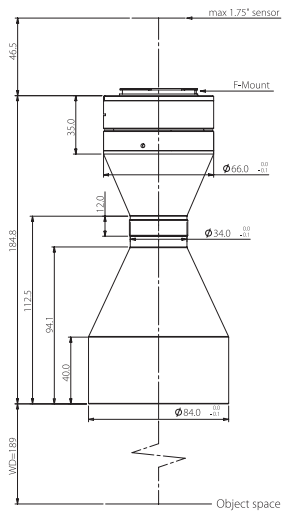

FOV(Φmm)	64
Mag.(x)	0.453
WD(mm)	189±3
Max Sensor Size(Φmm)	29(1.75")
F/#	17.1
MTF30(lp/mm)	>48
DoF(mm)	±3.8@F20
Distortion(% max)	<0.1
Telecentricity(° max)	<0.1
I/O(mm)	420±3
Length(mm)	184.8
Mount	F-Mount/Other
Weight(kg)	1.2

Field of View(mm xmm)	
1.75"CMV12000(22.53x16.90)	49.7x37.3
1.75"PYTHON16k(18.43x18.43)	40.7x40.7
1.75"LineScan-2k/4k/8k(28.8)	63.6

## BTL-0.403X-178-175(LM)

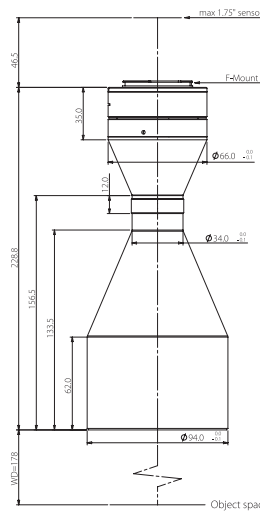

FOV(Φmm)	72
Mag.(x)	0.403
WD(mm)	178±3
Max Sensor Size(Φmm)	29(1.75")
F/#	8.5
MTF30(lp/mm)	>105
DoF(mm)	±3.9@F16
Distortion(% max)	<0.1
Telecentricity(° max)	<0.1
I/O(mm)	453±3
Length(mm)	228.8
Mount	F-Mount/Other
Weight(kg)	1.5

Field of View(mm xmm)	
1.75"CMV12000(22.53x16.90)	55.9x41.9
1.75"PYTHON16k(18.43x18.43)	45.7x45.7
1.75"LineScan-2k/4k/8k(28.8)	71.5

## BTL-0.363X-228-175(LM)

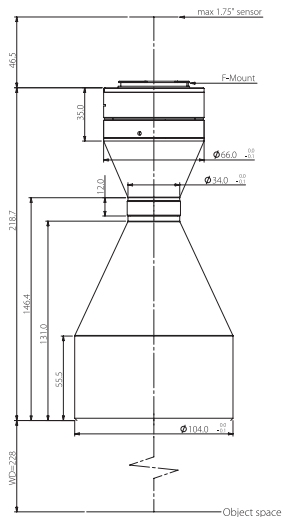

FOV(Φmm)	80
Mag.(x)	0.363
WD(mm)	228±4
Max Sensor Size(Φmm)	29(1.75")
F/#	17.1
MTF30(lp/mm)	>50
DoF(mm)	±6.0@F20
Distortion(% max)	<0.1
Telecentricity(° max)	<0.1
I/O(mm)	493±4
Length(mm)	218.7
Mount	F-Mount/Other
Weight(kg)	1.9

Field of View(mm xmm)	
1.75"CMV12000(22.53x16.90)	62.1x46.6
1.75"PYTHON16k(18.43x18.43)	50.8x50.8
1.75"LineScan-2k/4k/8k(28.8)	79.3

## BTL-0.322X-208-175(LM)

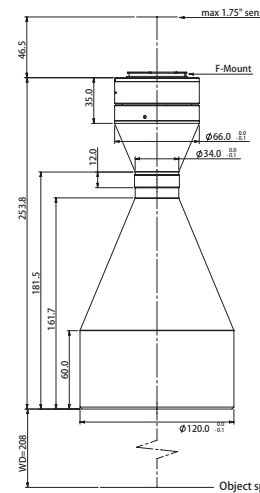

FOV(Φmm)	90
Mag.(x)	0.322
WD(mm)	208±3
Max Sensor Size(Φmm)	29(1.75")
F/#	8.5
MTF30(lp/mm)	>100
DoF(mm)	±6.1@F16
Distortion(% max)	<0.1
Telecentricity(° max)	<0.1
I/O(mm)	508±3
Length(mm)	253.8
Mount	F-Mount/Other
Weight(kg)	2.1

Field of View(mm xmm)	
1.75"CMV12000(22.53x16.90)	70.0x52.5
1.75"PYTHON16k(18.43x18.43)	57.2x57.2
1.75"LineScan-2k/4k/8k(28.8)	89.4

## BTL-0.29X-258-175(LM)

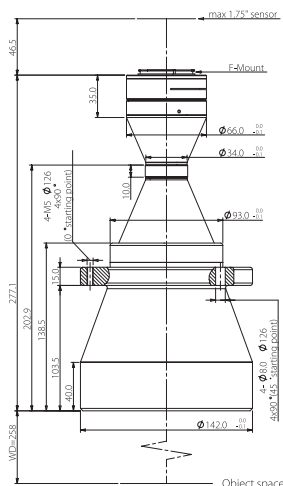

FOV(Φmm)	100
Mag.(x)	0.290
WD(mm)	258±4
Max Sensor Size(Φmm)	29(1.75")
F/#	11.3
MTF30(lp/mm)	>70
DoF(mm)	±9.5@F20
Distortion(% max)	<0.1
Telecentricity(° max)	<0.1
I/O(mm)	582±4
Length(mm)	277.1
Mount	F-Mount/Other
Weight(kg)	3.5

Field of View(mm xmm)	
1.75"CMV12000(22.53x16.90)	77.7x58.3
1.75"PYTHON16k(18.43x18.43)	63.6x63.6
1.75"LineScan-2k/4k/8k(28.8)	99.3

## BTL-0.242X-280-175(LM)

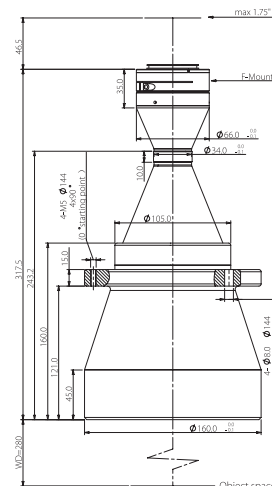

FOV(Φmm)	120
Mag.(x)	0.242
WD(mm)	280±5
Max Sensor Size(Φmm)	29(1.75")
F/#	9.7
MTF30(lp/mm)	>90
DoF(mm)	±13.6@F20
Distortion(% max)	<0.1
Telecentricity(° max)	<0.1
I/O(mm)	644±5
Length(mm)	317.5
Mount	F-Mount/Other
Weight(kg)	4.6

Field of View(mm xmm)	
1.75"CMV12000(22.53x16.90)	93.1x69.8
1.75"PYTHON16k(18.43x18.43)	76.2x76.2
1.75"LineScan-2k/4k/8k(28.8)	119.0

### BTL-0.193X-300-175(LM)

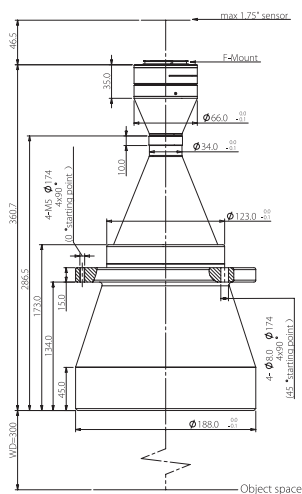

FOV(Φmm)	150
Mag.(x)	0.193
WD(mm)	300±5
Max Sensor Size(Φmm)	29(1.75")
F/#	9.7
MTF30(lp/mm)	>90
DoF(mm)	±21.5@F20
Distortion(% max)	<0.1
Telecentricity(° max)	<0.1
I/O(mm)	707±5
Length(mm)	360.7
Mount	F-Mount/Other
Weight(kg)	6.1

Field of View(mmxmm)	
1.75°CMV12000(22.53x16.90)	116.7x87.6
1.75°PYTHON16k(18.43x18.43)	95.5x95.5
1.75°LineScan-2k/4k/8k(28.8)	149.2

### BTL-0.153X-330-175(LM)

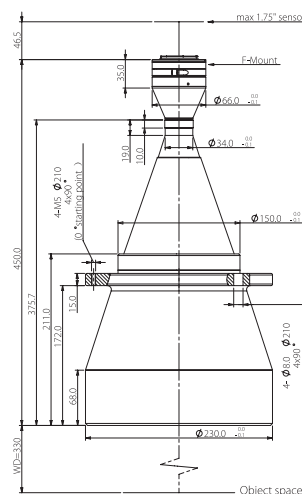

FOV(Φmm)	190
Mag.(x)	0.153
WD(mm)	330±5
Max Sensor Size(Φmm)	29(1.75")
F/#	6.8
MTF30(lp/mm)	>130
DoF(mm)	±27.3@F16
Distortion(% max)	<0.1
Telecentricity(° max)	<0.1
I/O(mm)	827±5
Length(mm)	450.0
Mount	F-Mount/Other
Weight(kg)	11.4

Field of View(mmxmm)	
1.75°CMV12000(22.53x16.90)	147.3x110.5
1.75°PYTHON16k(18.43x18.43)	120.5x120.5
1.75°LineScan-2k/4k/8k(28.8)	188.2

### BTL-0.121X-410-175(LM)

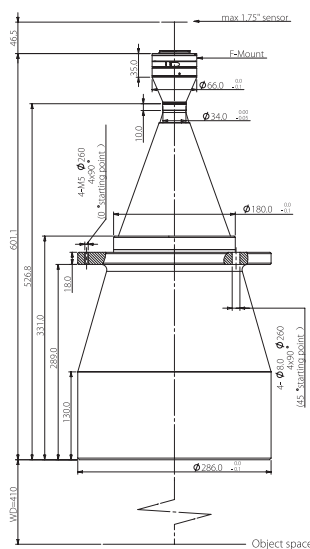

FOV(Φmm)	240
Mag.(x)	0.121
WD(mm)	410±6
Max Sensor Size(Φmm)	29(1.75")
F/#	6.8
MTF30(lp/mm)	>130
DoF(mm)	±43.7@F16
Distortion(% max)	<0.1
Telecentricity(° max)	<0.1
I/O(mm)	1058±6
Length(mm)	601.1
Mount	F-Mount/Other
Weight(kg)	25.9

Field of View(mmxmm)	
1.75°CMV12000(22.53x16.90)	186.2x139.7
1.75°PYTHON16k(18.43x18.43)	152.3x152.3
1.75°LineScan-2k/4k/8k(28.8)	238.0

### BTL-0.097X-465-175(LM)

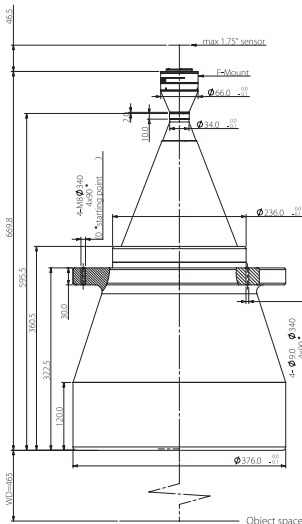

FOV(Φmm)	300
Mag.(x)	0.097
WD(mm)	465±6
Max Sensor Size(Φmm)	29(1.75")
F/#	8.5
MTF30(lp/mm)	>105
DoF(mm)	±68@F16
Distortion(% max)	<0.1
Telecentricity(° max)	<0.1
I/O(mm)	1181±6
Length(mm)	669.8
Mount	F-Mount/Other
Weight(kg)	47.0

Field of View(mmxmm)	
1.75°CMV12000(22.53x16.90)	232.3x174.2
1.75°PYTHON16k(18.43x18.43)	190.0x190.0
1.75°LineScan-2k/4k/8k(28.8)	296.9