

CONTRASTECH

LEO Series Area Scan Cameras



- Excellent cost performance ratio
- USB3.0 / GigE / 10-GigE / CameraLink / CoaXPress
- VGA to 150MP
- Advanced I / O Control

LEO Series

Contrastech LEO Series

Area Scan Cameras

Brief Introduction

With the wide application and popularization of machine vision technology, more and more higher requirements proposed by industrial applications, like high precision measurements and high speed inspection. Depend on decade technology accumulation efforts from former cameras, Contrastech has developed a new series cameras - LEO Series which available in the market to answer different challenges.

LEO series area scan cameras, equipped with the advanced high-end image sensor and covering a range of resolution from 0.3MP to 150MP, can meet various machine vision application requirements.

With the LEO series, you can choose from the most popular data interfaces in the Vision Market: the Gigabit Ethernet interface with 100 meter cable length and the USB 3.0 interface with plug and play capability. All of these interfaces are standardized and offer the option to provide power and data to the camera via one single cable. The cameras also offer separate input/output ports for triggering or flash control.

Applications

Defect inspection; SMT;
Vision localization;
Dimension measurement;
Barcode reading;
VR/AR;
Logistic Industry

LEO Series industrial cameras compatible with GigE, USB3.0, 10GigE, Camera Link and CoaXPress data bus standards, support GenICam, GigE Vision®, can smoothly connect with third-party software, like HALCON, Vision Pro etc., without secondary development. LEO Series cameras with excellent cost performance and fully suitable for various inspection, measurements and high-speed imaging applications. This series cameras won customers high praise because its perfect performance in cellphone and tablet PC screen inspection, LED automatic packing, defect inspection, electronic components manufacturing, wafer positioning and other applications.

With this variety of sensors and interfaces, combined with the extensive features offered, LEO series is fit for a wide range of vision applications.

Main Feature

Wide Range of Resolution

Resolution from 0.3MP to 150MP for Various Applications.

High Quality Sensors

Latest Kodark, Onsemi Series Sensors, Sony Pregius Series Sensors.

High Frame Rate, Up to 815fps

High Frame Rate Ideal for High-speed Application.

128 MB RAM

Internal memory up to 128 MB guarantees no image loss.

Excellent Cost Performance.



Contrastech LEO Series

Area Scan Cameras

GigE								
Model	Resolution	Fps	Sensor Size	Pixel Size	Sensor	Sensor Technology	Color	No.
LEO 640P-173gm/gc	640 × 480	173	1/3.6	4.8	PYTHON 300	Global CMOS	Mono / Color	5
LEO 640H-200gm/gc	640 × 480	200	1/3	7.4	RJ33	Global CCD	Mono / Color	5
LEO 640P-344gm	672 × 512	344	1/4	4.8	PYTHON 300	Global CMOS	Mono	5
LEO 640P-336gc	672 × 512	336	1/4	4.8	PYTHON 300	Global CMOS	Color	5
LEO 720S-313gm/gc	720 × 540	312.9	1/2.9	6.9	IMX287	Global CMOS	Mono / Color	5
LEO 800P-116gm/gc	808 × 608	116	1/3.6	4.8	PYTHON 480	Global CMOS	Mono / Color	6
LEO 1200H-30gm/gc	1280 × 960	30	1/3	3.75	RJ33	Global CCD	Mono / Color	6
LEO 1300P-90gm/gc/gNIR	1280 × 1024	90	1/2	4.8	PYTHON 1300	Global CMOS	Mono / Color / NIR	6
LEO 1300E-50gm	1280 × 1024	49	1	10	E2V	Global CMOS	Mono	6
LEO 1440S-78gm/gc	1440 × 1080	78.2	1/2.9	3.45	IMX273	Global CMOS	Mono / Color	7
LEO 2000S-60gm/gc	1624 × 1240	60	1/1.7	4.5	IMX430	Global CMOS	Mono / Color	7
LEO 2000P-53gm/gc	1920 × 1200	52.7	2/3	4.8	PYTHON 2000	Global CMOS	Mono / Color	7
LEO 2000S-58gc	1920 × 1080	58	1/2.8	2.9	IMX290	Rolling CMOS	Color	7
LEO 2300S-41gm/gc	1920 × 1200	41	1/1.2	5.86	IMX249	Global CMOS	Mono / Color	8
LEO 3000S-38gm/gc	2048 × 1536	37.5	1/1.8	3.45	IMX265	Global CMOS	Mono / Color	8
LEO 5000A-14gm	2592 × 1944	14	1/2.5	2.2	MT9P031	Rolling CMOS	Mono	8
LEO 5000A-24gm/gc	2592 × 1944	24	1/2.5	2.2	AR0521	Rolling CMOS	Mono / Color	8
LEO 5000S-24gm/gc	2448 × 2048	23.5	2/3	3.45	IMX264	Global CMOS	Mono / Color	8
LEO 5000P-22gm/gc/gNIR	2592 × 2048	22	1	4.8	PYTHON 5000	Global CMOS	Mono / Color / NIR	9
LEO 6000S-17gm/gc	3072 × 2048	17	1/1.8	2.4	IMX178	Rolling CMOS	Mono / Color	9
LEO 3840A-7gm/gc	3840 × 2748	7	1/2.3	1.67	MT9J003	Rolling CMOS	Mono / Color	9
LEO 3840A-11gm	3840 × 2748	11.2	1/2.3	1.67	MT9J003	Rolling CMOS	Mono	9
LEO 4020S-10gm/gc	4024 × 3036	9.6	1/1.7	1.85	IMX226	Rolling CMOS	Mono / Color	10
LEO 5470S-6gms	5472 × 3648	5.9	1	2.4	IMX183	Rolling CMOS	Mono	10
LEO 5470S-6gm/gc	5472 × 3648	5.9	1	2.4	IMX183	Rolling CMOS	Mono / Color	10
LEO 5120G-5gm	5120 × 5120	4.5	1.1	2.5	GMAX0505	Global CMOS	Mono	10
LEO 8MK-14gm/gc	3296 × 2472	14	4/3	5.5	KAI-08051	Global CCD	Mono / Color	11
LEO 9MS-13gm/gc	4096 × 2160	13	1	3.45	IMX267	Global CMOS	Mono / Color	11
LEO 12MS-9gm/gc	4096 × 3000	9.4	1.1	3.45	IMX304	Global CMOS	Mono / Color	11
LEO 25MP-5gm/gc	5120 × 5120	4.6	23 × 23 mm	4.5	PYTHON25K	Global CMOS	Mono / Color	12
LEO 29MK-4gm/gc ¹	6576 × 4384	4	36 × 24 mm	5.5	KAI-29050	Global CCD	Mono / Color	12
LEO 31MS-4gm/gc	6464 × 4852	3.9	APS-C	3.45	IMX342	Global CMOS	Mono / Color	12

¹:Divided into high and low level sensors

Contrastech LEO Series

Area Scan Cameras

USB3.0

Model	Resolution	Fps	Sensor Size	Pixel Size	Sensor	Sensor Technology	Color	No.
LEO 640P-815um/uc	640 × 480	814.5	1/4	4.8	PYTHON 300	Global CMOS	Mono / Color	13
LEO 720S-526um/uc	720 × 540	526.5	1/2.9	6.9	IMX287	Global CMOS	Mono / Color	13
LEO 1200H-30um/uc	1280 × 960	30	1/3	3.75	RJ33	Global CCD	Mono / Color	13
LEO 1300M-150um/uc	1280 × 1024	150	1/2.7	4.0	SMS 031GS	Global CMOS	Mono / Color	13
LEO 1300P-210um/uc	1280 × 1024	210	1/2	4.8	PYTHON 1300	Global CMOS	Mono / Color	14
LEO 1440S-250um/uc	1440 × 1080	249.1	1/2.9	3.45	IMX273	Global CMOS	Mono / Color	14
LEO 2000S-89um/uc	1624 × 1240	89.1	1/1.7	4.5	IMX430	Global CMOS	Mono / Color	14
LEO 2300S-40um	1920 × 1200	41	1/1.2	5.86	IMX249	Global CMOS	Mono	15
LEO 2300S-40uc	1920 × 1200	40	1/1.2	5.86	IMX249	Global CMOS	Color	15
LEO 5000S-35um/uc	2448 × 2048	35.1	2/3	3.45	IMX264	Global CMOS	Mono / Color	15
LEO 5000A-45um/uc	2592 × 1944	44.7	1/2.5	2.2	AR0521	Rolling CMOS	Mono / Color	15
LEO 5000P-72um/uc	2592 × 2048	71.8	1	4.8	PYTHON 5000	Global CMOS	Mono / Color	15
LEO 5000S-74um/uc	2448 × 2048	74	2/3	3.45	IMX250	Global CMOS	Mono / Color	16
LEO 6000S-43um/uc	3072 × 2048	42.7	1/1.8	2.4	IMX178	Rolling CMOS	Mono / Color	16
LEO 4020S-32um/uc	4000 × 3036	31.9	1/1.7	1.85	IMX226	Rolling CMOS	Mono / Color	16
LEO 5470S-19ums	5472 × 3648	19.2	1	2.4	IMX183	Rolling CMOS	Mono / Color	16
LEO 5470S-19um/uc	5472 × 3648	19.2	1	2.4	IMX183	Rolling CMOS	Mono / Color	17
LEO 9MS-32um/uc	4096 × 2160	32	1	3.45	IMX267	Global CMOS	Mono / Color	17
LEO 12MS-23um/uc	4096 × 3000	23.1	1.1	3.45	IMX304	Global CMOS	Mono / Color	17

Camera Link

Model	Resolution	Fps	Sensor Size	Pixel Size	Sensor	Sensor Technology	Color	No.
LEO 5000S-140cm/cc	2432 × 2048	140	2/3	3.45	IMX250	Global CMOS	Mono / Color	18
LEO 1200S-70cm	3840 × 3000	69.8	1.1"	3.45	IMX253	Global CMOS	Mono	18
LEO 1200S-70cc	3840 × 3000	68.1	1.1"	3.45	IMX253	Global CMOS	Color	18
LEO 29MK-5cm/cc ¹	6576 × 4384	4.5	36 × 24 mm	5.5	KAI-29050	Global CCD	Mono / Color	19
LEO 43MK-4cm	8032 × 5360	3.64	36 × 24 mm	4.5	KAI-43140	Global CCD	Mono	19
LEO 50MK-4cm	10440 × 4800	4	46.98 × 21.60 mm	4.5	KAI-50140	Global CCD	Mono	19

¹:Divided into high and low level sensors

CoaXPress

Model	Resolution	Fps	Sensor Size	Pixel Size	Sensor	Sensor Technology	Color	No.
LEO 31MS-17xm-F	6464 × 4852	17.9	APS-C	3.45	IMX342	Global CMOS	Mono	20
LEO 43MG-17xm-F	7904 × 5432	16.35	22.16 × 15.22 mm	2.8	GMAX0806	Global CMOS	Mono	20
LEO 65MG-31xm	9216 × 7000	31.5	29.9 × 22.4 mm	3.2	GMAX3265	Global CMOS	Mono	20
LEO 150MS-6xc-M72	14208 × 10640	6.2	66.7 mm	3.76	IMX411	Rolling CMOS	Color	20

10 GigE

Model	Resolution	Fps	Sensor Size	Pixel Size	Sensor	Sensor Technology	Color	No.
LEO 12MS-68tgm	4096 × 3000	68	1.1	3.45	IMX253	Global CMOS	Mono	21
LEO 25MP-40tgc	5120 × 5120	40	23 × 23mm	4.5	PYTHON25K	Global CMOS	Color	21
LEO 25MP1-40tgm	5120 × 5120	40	23 × 23mm	4.5	PYTHON25K	Global CMOS	Mono	21

Contrastech LEO Series

Area Scan Cameras

Specifications



Model	LEO 640P-173gm/gc	LEO 640P-344gm	LEO 640P-336gc	LEO 640H-200gm/gc	LEO 720S-313gm/gc
Camera					
Resolution (H*V)	640 × 480	672 × 512	670 × 512	640 × 480	720 × 540
Sensor	ON Semiconductor PYTHON 300	ON Semiconductor PYTHON 300	ON Semiconductor PYTHON 300	Sharp RJ33	SONY IMX287
Sensor Size (optical)	1/3.6"	1/4"	1/4"	1/3"	1/2.9"
Sensor Technology	CMOS, Global	CMOS, Global	CMOS, Global	CCD, Global	CMOS, Global
Pixel Size [μm]	4.8 × 4.8	4.8 × 4.8	4.8 × 4.8	7.4 × 7.4	6.9 × 6.9
Frame Rate [fps]	173	344	336	200	312.9
Data Bits	8bit / 10bit / 12bit	8bit / 10bit / 12bit	8bit / 10bit / 12bit	8bit / 10bit / 12bit	8bit / 10bit / 12bit
Exposure Time	42μs~10s	49μs~10s	40μs~10s	20μs~1s	1μs~10s
Dynamic Range	<60dB	<60dB	<60dB	52dB	74dB
Color	Mono / Color	Mono	Color	Mono / Color	Mono / Color
Image Format	Mono: Mono8/10/10p/12/12p Color: Mono 8/10/12,Bayer RG 8/10/10p/12/12p Color: Mono 8/10/12,Bayer GB 8/10/10p/12/12p (For LEO 640H-200gc)				
Interface	Gigabit Ethernet (1000 Mbit/s)				
Synchronization	Via hardware trigger, via software trigger or free run				
Programmable Control [ISP]	Image Resolution, RGB gain, Exposure Time, Contrast, Gamma Chart, Image Rollover, Raw, LUT, Black Level Correction.				
Electrical					
Housing Size[L*W*H]	42.0×29.0×29.0 mm (65g) (*A)				
Operating Temperature	-30~70 ° C (Storage), 0~50° C (Working)				
Lens Mount	C-Mount				
Digital I/O	1 opto-isolated input, 1 opto-isolated output, 1 bidirectional custom non-isolation I/O				
Power Input	DC 12V, POE				DC 9-24V, POE
Power Consumption	12V @3.0W	12V @2.5W	12V @2.5W	12V @3.5W	12V @3.0W
Driver	LEO Series camera Software Suite (iDatum) or 3rd party GigE Vision Software				
Operating System	Windows, Linux, Arm				
Conformity	GigE Vision, GenICam				

Contrastech LEO Series

Area Scan Cameras



Specifications

Model	LEO 800P-116gm/gc	LEO 1200H-30gm/gc	LEO 1300P-90gm/gc/gNIR	LEO 1300E-50gm
Camera				
Resolution (H*V)	808 × 608	1280 × 960	1280 × 1024	1280 × 1024
Sensor	ON Semiconductor PYTHON 480	Sharp RJ33	ON Semiconductor PYTHON 1300	E2V
Sensor Size (optical)	1/3.6"	1/3"	1/2"	1"
Sensor Technology	CMOS, Global	CCD, Global	CMOS, Global	CMOS, Global
Pixel Size [μm]	4.8 × 4.8	3.75 × 3.75	4.8 × 4.8	10 × 10
Frame Rate [fps]	116	30	90	49
Data Bits	8bit / 10bit / 12bit	8bit / 10bit / 12bit	8bit / 10bit / 12bit	8bit / 10bit / 12bit
Exposure Time	42μs~10s	34μs~1s	Mono: 38μs~10s Color : 62μs~10s	20μs~1s
Dynamic Range	<60dB	60dB	<60dB	>70dB
Color	Mono / Color	Mono / Color	Mono / Color / NIR	Mono
Image Format	Mono: Mono8/10/10p/12/12p Color: Mono 8/10/12,Bayer RG 8/10/10p/12/12p Color: Mono 8/10/12,Bayer GR 8/10/10p/12/12p(For LEO 1200H-30gc)			
Interface	Gigabit Ethernet (1000 Mbit/s)			
Synchronization	Via hardware trigger, via software trigger or free run			
Programmable Control [ISP]	Image Resolution, RGB gain, Exposure Time, Contrast, Gamma Chart, Image Rollover, Raw, LUT, Black Level Correction.			
Electrical				
Housing Size[L*W*H]	42.0×29.0×29.0 mm (65g) (*A)			44.0×39.0×60.0 mm (140g) (*D)
Operating Temperature	-30~70 ° C (Storage), 0~50° C (Working)			
Lens Mount	C-Mount			
Digital I/O	1 opto-isolated input, 1 opto-isolated output, 1 bidirectional custom non-isolation I/O			
Power Input	DC 12V, POE			DC 5-15V, POE
Power Consumption	12V @<3.0W	12V @2.5W	12V @<2.7W	12V @<3.7W
Driver	LEO Series camera Software Suite (iDatum) or 3rd party GigE Vision Software			
Operating System	Windows, Linux,Arm			
Conformity	GigE Vision, GenICam			

Contrastech LEO Series

Area Scan Cameras



Specifications

Model	LEO 1440S-78gm/gc	LEO 2000S-60gm/gc	LEO 2000P-53gm/gc	LEO 2000S-58gc
Camera				
Resolution (H*V)	1440 × 1080	1624 × 1240	1920 × 1200	1920 × 1080
Sensor	SONY IMX273	SONY IMX430	ON Semiconductor PYTHON 2000	SONY IMX290
Sensor Size (optical)	1/2.9"	1/1.7"	2/3"	1/2.8"
Sensor Technology	CMOS, Global	CMOS, Global	CMOS, Global	CMOS, Rolling
Pixel Size [μm]	3.45 × 3.45	4.5 × 4.5	4.8 × 4.8	2.9 × 2.9
Frame Rate [fps]	78.2	60	52.7	58
Data Bits	8bit / 10bit / 12bit	8bit / 10bit / 12bit	8bit / 10bit / 12bit	8bit / 10bit / 12bit
Exposure Time	1μs~10s	1μs~10s	59μs~10s	15μs~2s
Dynamic Range	>70dB	>70dB	<60dB	74dB
Color	Mono / Color	Mono / Color	Mono / Color	Color
Image Format	Mono: Mono8/10/10p/12/12p Color: Mono 8/10/12,Bayer RG 8/10/10p/12/12p Color: Mono 8/10/12,Bayer BG 8/10/10p/12/12p(For LEO 2000P-53gc)			
Interface	Gigabit Ethernet (1000 Mbit/s)			
Synchronization	Via hardware trigger, via software trigger or free run			
Programmable Control [ISP]	Image Resolution, RGB gain, Exposure Time, Contrast, Gamma Chart, Image Rollover, Raw, LUT, Black Level Correction.			
Electrical				
Housing Size[L*W*H]	42.0×29.0×29.0 mm (65g) (*A)			
Operating Temperature	-30~70 ° C (Storage), 0~50° C (Working)			
Lens Mount	C-Mount			
Digital I/O	1 opto-isolated input, 1 opto-isolated output, 1 bidirectional custom non-isolation I/O			
Power Input	DC 9-24V, POE	DC 9-24V, POE	DC 12V, POE	DC 9-24V, POE
Power Consumption	12V @<3.0W	Mono: 12V @<3.2W Color: 12V @<3.6W	12V @<3.0W	12V @<2.4W
Driver	LEO Series camera Software Suite (iDatum) or 3rd party GigE Vision Software			
Operating System	Windows, Linux,Arm			
Conformity	GigE Vision, GenICam			

Contrastech LEO Series

Area Scan Cameras

Specifications



Model	LEO 2300S-41gm/gc	LEO 3000S-38gm/gc	LEO 5000A-14gm	LEO 5000A-24gm/gc	LEO 5000S-24gm/gc
Camera					
Resolution (H*V)	1920 × 1200	2048 × 1536	2592 × 1944	2592 × 1944	2448 × 2048
Sensor	SONY IMX249	SONY IMX265	Aptina MT9P031	Aptina AR0521	SONY IMX264
Sensor Size (optical)	1/1.2"	1/1.8"	1/2.5"	1/2.5"	2/3"
Sensor Technology	CMOS, Global	CMOS, Global	CMOS, Rolling	CMOS, Rolling	CMOS, Global
Pixel Size [μm]	5.86 × 5.86	3.45 × 3.45	2.2 × 2.2	2.2 × 2.2	3.45 × 3.45
Frame Rate [fps]	41	37.5	14	24	23.5
Data Bits	8bit / 10bit / 12bit	8bit / 10bit / 12bit	8bit / 10bit / 12bit	8bit / 10bit / 12bit	8bit / 10bit / 12bit
Exposure Time	34μs~10s	15μs~10s	34μs~1s	21μs~1s	15μs~10s
Dynamic Range	70dB	>70dB	60dB	>60dB	>70dB
Color	Mono / Color	Mono / Color	Mono	Mono / Color	Mono / Color
Image Format	Mono: Mono8/10/10p/12/12p Color: Mono8/10/12,Bayer RG 8/10/10p/12/12p Color: Mono 8/10/12,Bayer GB 8/10/10p/12/12p (For LEO 5000A-24gc)				
Interface	Gigabit Ethernet (1000 Mbit/s)				
Synchronization	Via hardware trigger, via software trigger or free run				
Programmable Control [ISP]	Image Resolution, RGB gain, Exposure Time, Contrast, Gamma Chart, Image Rollover, Raw, LUT, Black Level Correction.				
Electrical					
Housing Size[L*W*H]	42.0×29.0×29.0 mm (65g) (*A)				
Operating Temperature	-30~70 ° C (Storage), 0~50° C (Working)				
Lens Mount	C-Mount				
Digital I/O	1 opto-isolated input, 1 opto-isolated output, 1 bidirectional custom non-isolation I/O				
Power Input	DC 12V, POE			DC 9-24V, POE	DC 12V, POE
Power Consumption	12V @<3.0W	12V @<3.5W	12V @<3.0W	12V @<2.5W	12V @<3.2W
Driver	LEO Series camera Software Suite (iDatum) or 3rd party GigE Vision Software				
Operating System	Windows, Linux,Arm				
Conformity	GigE Vision, GenICam				

Contrastech LEO Series

Area Scan Cameras

Specifications



Model	LEO 5000P-22gm/gc	LEO 5000P-22gNIR	LEO 6000S-17gm/gc	LEO 3840A-7gm/gc	LEO 3840A-11gm
Camera					
Resolution (H*V)	2592 × 2048	2592 × 2048	3072 × 2048	3840 × 2748	3840 × 2748
Sensor	ON Semiconductor PYTHON 5000	ON Semiconductor PYTHON 5000	SONY IMX178	Aptina MT9J003	Aptina MT9J003
Sensor Size (optical)	1"	1"	1/1.8"	1/2.3"	1/2.3"
Sensor Technology	CMOS, Global	CMOS, Global	CMOS, Rolling	CMOS, Rolling	CMOS, Rolling
Pixel Size [µm]	4.8 × 4.8	4.8 × 4.8	2.4 × 2.4	1.67 × 1.67	1.67 × 1.67
Frame Rate [fps]	22	22	17	7	11.2
Data Bits	8bit / 10bit / 12bit	8bit / 10bit / 12bit	8bit / 10bit / 12bit	8bit / 10bit / 12bit	8bit / 10bit / 12bit
Exposure Time	65µs~10s	65µs~10s	27µs-2.5s	50µs~2s	26µs~1s
Dynamic Range	<58dB	<60dB	>70dB	65dB	65dB
Color	Mono / Color	NIR	Mono / Color	Mono / Color	Mono
Image Format	Mono: Mono8/10/10p/12/12p Color: Mono 8/10/12,Bayer BG 8/10/10p/12/12p Color: Mono 8/10/12,Bayer RG 8/10/10p/12/12p (For LEO 6000S-17gc) Color: Mono 8/10/12,Bayer GR 8/10/10p/12/12p (For LEO 3840A-7gc)				
Interface	Gigabit Ethernet (1000 Mbit/s)				
Synchronization	Via hardware trigger, via software trigger or free run				
Programmable Control [ISP]	Image Resolution, RGB gain, Exposure Time, Contrast, Gamma Chart, Image Rollover, Raw, LUT, Black Level Correction.				
Electrical					
Housing Size[L*W*H]	Gamma Chart, Image Rollover, Raw, LUT, Black Level Correction.				
Operating Temperature	-30~70 ° C (Storage), 0~50° C (Working)				
Lens Mount	C-Mount				
Digital I/O	1 opto-isolated input, 1 opto-isolated output, 1 bidirectional custom non-isolation I/O				
Power Input	DC 12V, POE				
Power Consumption	12V @<3.3W	12V @<3.3W	Mono: 12V @<2.5W Color: 12V @<3.5W	12V @<2.5W	12V @<2.5W
Driver	LEO Series camera Software Suite (iDatum) or 3rd party GigE Vision Software				
Operating System	Windows, Linux,Arm				
Conformity	GigE Vision, GenICam				

Contrastech LEO Series

Area Scan Cameras



Specifications

Model	LEO 4020S-10gm/gc	LEO 5470S-6gms	LEO 5470S-6gm/gc	LEO 5120G-5gm
Camera				
Resolution (H*V)	4024 × 3036	5472 × 3648	5472 × 3648	5120 × 5120
Sensor	SONY IMX226	SONY IMX183	SONY IMX183	Gpixel GMAX0505
Sensor Size (optical)	1/1.7"	1"	1"	1.1"
Sensor Technology	CMOS, Rolling	CMOS, Rolling	CMOS, Rolling	CMOS, Rolling
Pixel Size [µm]	1.85 × 1.85	2.4 × 2.4	2.4 × 2.4	2.5 × 2.5
Frame Rate [fps]	9.6	5.9	5.9	4.5
Data Bits	8bit / 10bit / 12bit	8bit / 10bit / 12bit	8bit / 10bit / 12bit	8bit / 10bit / 12bit
Exposure Time	34µs~2s	46µs~2s	46µs~2s	12µs~10s
Dynamic Range	>70dB	>65dB	>65dB	>60dB
Color	Mono / Color	Mono	Mono / Color	Mono
Image Format	Mono: Mono8/10/10p/12/12p Color: Mono 8/10/12,Bayer GB 8/10/10p/12/12p			
Interface	Gigabit Ethernet (1000 Mbit/s)			
Synchronization	Via hardware trigger, via software trigger or free run			
Programmable Control [ISP]	Image Resolution, RGB gain, Exposure Time, Contrast, Gamma Chart, Image Rollover, Raw, LUT, Black Level Correction.			
Electrical				
Housing Size[L*W*H]	42.0×29.0×29.0 mm (65g) (*A)		44.0×29.0×60.0 mm (100g) (*C1)	
Operating Temperature	-30~70 ° C (Storage), 0~50° C (Working)			
Lens Mount	C-Mount			
Digital I/O	1 opto-isolated input, 1 opto-isolated output, 1 bidirectional custom non-isolation I/O			
Power Input	DC 12V, POE	DC 9-24V, POE	DC 12V, POE	
Power Consumption	12V @<2.7W	12V @<3.0W	Mono: 12V @<3.1W Color: 12V @<3.5W	12V @<3.6W
Driver	LEO Series camera Software Suite (iDatum) or 3rd party GigE Vision Software			
Operating System	Windows, Linux,Arm			
Conformity	GigE Vision, GenICam			

Contrastech LEO Series

Area Scan Cameras



Specifications

Model	LEO 8MK-14gm/gc	LEO 9MS-13gm/gc	LEO 12MS-9gm/gc
Camera			
Resolution (H*V)	3296 × 2472	4096 × 2160	4096 × 3000
Sensor	ON Semiconductor KAI-08051	SONY IMX267	SONY IMX304
Sensor Size (optical)	4/3"	1"	1.1"
Sensor Technology	CCD, Global	CMOS, Global	CMOS, Global
Pixel Size [μm]	5.5 × 5.5	3.45 × 3.45	3.45 × 3.45
Frame Rate [fps]	14	13	9.4
Data Bits	8bit / 10bit / 12bit	8bit / 10bit / 12bit	8bit / 10bit / 12bit
Exposure Time	50μs~1s	15μs~10s	15μs~10s
Dynamic Range	66dB	>72dB	>72dB
Color	Mono / Color	Mono / Color	Mono / Color
Image Format	Mono: Mono8/10/10p/12/12p Color: Mono 8/10/12,Bayer RG 8/10/10p/12/12p Color: Mono 8/10/12,Bayer GR 8/10/10p/12/12p (For LEO 8MK-14gc)		
Interface	Gigabit Ethernet (1000 Mbit/s)		
Synchronization	Via hardware trigger, via software trigger or free run		
Programmable Control [ISP]	Image Resolution, RGB gain, Exposure Time, Contrast, Gamma Chart, Image Rollover, Raw, LUT, Black Level Correction.		
Electrical			
Housing Size[L*W*H]	M58:(Standard)74.0×74.0×47.5 mm (*F) M58:(Air-cooling)74.0×74.0×75.3 mm (*I)	44.0×29.0×60.0 mm (100g) (*C1)	
Operating Temperature	-30~70 ° C (Storage), 0~50° C (Working)		
Lens Mount	M58(C/F-mount Transferable)	C-Mount	
Digital I/O	1 opto-isolated input/output,1 RS232, 1 bidirectional custom non-isolation I/O,	1 opto-isolated input, 1 opto-isolated output, 1 bidirectional custom non-isolation I/O	
Power Input	DC 12V 2A	DC 12V, POE	
Power Consumption	12V @11.7W	Mono: 12V @<3.5W Color: 12V @<3.8W	Mono: 12V @<4.3W Color: 12V @<4.6W
Driver	LEO Series camera Software Suite (iDatum) or 3rd party GigE Vision Software		
Operating System	Windows, Linux,Arm		
Conformity	GigE Vision, GenICam		

Contrasttech LEO Series

Area Scan Cameras

Specifications



Model	LEO 25MP-5gm/gc	LEO 29MK-4gm/gc	LEO 29MK1-4gm	LEO 31MS-4gm/gc
Camera				
Resolution (H*V)	5120 × 5120	6576 × 4384	6576 × 4384	6464 × 4852
Sensor	ON Semiconductor PYTHON 25K	KAI-29050	KAI-29050	SONY IMX342
Sensor Size (optical)	23mm × 23mm	36mm × 24mm	36mm × 24mm	22.3mm × 16.7mm
Sensor Technology	CMOS, Global	CCD, Global	CCD, Global	CMOS, Global
Pixel Size [μm]	4.5 × 4.5	5.5 × 5.5	5.5 × 5.5	3.45 × 3.45
Frame Rate [fps]	4.64	4	4	3.9
Data Bits	8bit / 10bit / 12bit	8bit / 10bit / 12bit	8bit / 10bit / 12bit	8bit / 10bit / 12bit
Exposure Time	80μs~10s	110μs~5s	110μs~1s	Mono: 36μs~2s Color: 36μs~10s
Dynamic Range	58dB	64dB	64dB	>72dB
Color	Mono / Color	Mono / Color	Mono	Mono / Color
Image Format	Mono: Mono8/10/10p/12/12p Color: Mono 8/10/12,Bayer RG 8/10/10p/12/12p			
Interface	Gigabit Ethernet (1000 Mbit/s)			
Synchronization	Via hardware trigger, via software trigger or free run			
Programmable Control [ISP]	Image Resolution, RGB gain, Exposure Time, Contrast, Gamma Chart, Image Rollover, Raw, LUT, Black Level Correction.			
Electrical				
Housing Size[L*W*H]	M58:(Air-cooling) 74.0×74.0×72.7 mm (*J) F:(Air-cooling) 74.0×74.0×78.7 mm (*K)	M58:(Standard)74.0×74.0×47.5 mm (*F) / (Air-cooling)74.0×74.0×75.3 mm (*I) F:(Standard) 74.0×74.0×53.9 mm (*U) / (Air-cooling) 74.0×74.0×81.7 mm (*V)		F:(Air-cooling) 74.0×74.0×80.1 mm (*W)
Operating Temperature	-30~70 ° C (Storage), 0~50° C (Working)			
Lens Mount	M58 / F-mount	M58 / F-mount	M58 / F-mount	F-mount
Digital I/O	1 opto-isolated input, 1 opto-isolated output, 1 bidirectional custom non-isolation I/O, 1 RS232			
Power Input	DC 12V	DC 12V 2A		DC 9-24V
Power Consumption	Mono: 12V @<6.7W Color: 12V @<7.8W	12V @12W	12V @12W	12V@<9W
Driver	LEO Series camera Software Suite (iDatum) or 3rd party GigE Vision Software			
Operating System	Windows, Linux,Arm			
Conformity	GigE Vision, GenICam			

Contrastech LEO Series

Area Scan Cameras

Specifications



Model	LEO 640P-815um/uc	LEO 720S-526um/uc	LEO 1200H-30um/uc	LEO 1300M-150um
Camera				
Resolution (H*V)	640 × 480	720 × 540	1280 × 960	1280 × 1024
Sensor	ON Semiconductor PYTHON 300	SONY IMX287	Sharp RJ33	SMS 031GS
Sensor Size (optical)	1/4"	1/2.9"	1/3"	1/2.7"
Sensor Technology	CMOS, Global	CMOS, Global	CCD, Global	CMOS, Global
Pixel Size [μm]	4.8 × 4.8	6.9 × 6.9	3.75 × 3.75	4.0 × 4.0
Frame Rate [fps]	814.5	526.5	30	150
Data Bits	8bit / 10bit / 12bit	8bit / 10bit / 12bit	8bit / 10bit / 12bit	8bit / 10bit / 12bit
Exposure Time	40μs~10s	15μs~10s	10μs~1s	30μs~10s
Dynamic Range	<60dB	74dB	60dB	60dB
Color	Mono / Color	Mono / Color	Mono / Color	Mono
Image Format	Mono: Mono8/10/10p/12/12p Color: Mono 8/10/12 Bayer RG 8/10/10p/12/12p Color: Mono 8/10/12, Bayer GR 8/10/10p/12/12p (For LEO 1200H-30uc)			
Interface	USB 3.0			
Synchronization	Via hardware trigger, via software trigger or free run			
Programmable Control [ISP]	Image Resolution, RGB gain, Exposure Time, Contrast, Gamma Chart, Image Rollover, Raw, LUT, Black Level Correction.			
Electrical				
Housing Size[L*W*H]	29.0×29.0×30.0 mm (55g) (*B)	29.0×29.0×30.0 mm (80g) (*B)	44.0×29.0×60.0 mm (100g) (*C2)	29.0×29.0×30.0 mm (55g) (*B)
Operating Temperature	-30~70 ° C (Storage), 0~50° C (Working)			
Lens Mount	C-Mount			
Digital I/O	1 opto-isolated input, 1 opto-isolated output, 1 bidirectional custom non-isolation I/O			
Power Input	DC 12V, USB	DC 9-24V, USB	DC 12V, USB	DC 12V, USB
Power Consumption	5V @3.3W	5V @3.0W	5V @<2.7W	5V @<1.9W
Driver	LEO Series camera Software Suite (iDatum) or 3rd party USB3 Vision Software			
Operating System	Windows, Linux, Arm			
Conformity	USB3 Vision, GenICam			

Contrastech LEO Series

Area Scan Cameras

Specifications



Model	LEO 1300P-210um/uc	LEO 1440S-250um/uc	LEO 2000S-89um/uc
Camera			
Resolution (H*V)	1280 × 1024	1440 × 1080	1624 × 1240
Sensor	ON Semiconductor PYTHON 1300	SONY IMX273	SONY IMX430
Sensor Size (optical)	1/2"	1/2.9"	1/1.7"
Sensor Technology	CMOS, Global	CMOS, Global	CMOS, Global
Pixel Size [µm]	4.8 × 4.8	3.45 × 3.45	4.5 × 4.5
Frame Rate [fps]	210	249.1	89.1
Data Bits	8bit / 10bit / 12bit	8bit / 10bit / 12bit	8bit / 10bit / 12bit
Exposure Time	Mono: 40µs~10s Color: 65µs~10s	15µs~10s	1µs~10s
Dynamic Range	<60dB	>70dB	>75dB
Color	Mono / Color	Mono / Color	Mono / Color
Image Format	Mono: Mono8/10/10p/12/12p Color: Mono 8/10/12,Bayer RG 8/10/10p/12/12p		
Interface	USB 3.0		
Synchronization	Via hardware trigger, via software trigger or free run		
Programmable Control [ISP]	Image Resolution, RGB gain, Exposure Time, Contrast, Gamma Chart, Image Rollover, Raw, LUT, Black Level Correction.		
Electrical			
Housing Size[L*W*H]	29.0×29.0×30.0 mm (55g) (*B)		29.0×29.0×30.0 mm (80g) (*B)
Operating Temperature	-30~70 ° C (Storage), 0~50° C (Working)		
Lens Mount	C-Mount		
Digital I/O	1 opto-isolated input, 1 opto-isolated output, 1 bidirectional custom non-isolation I/O		
Power Input	DC 12V, USB	DC 12V, USB	DC 9-24V, USB
Power Consumption	5V @3.0W	5V @2.8W	Mono: 5V @<3.2W Color: 5V @<3.9W
Driver	LEO Series camera Software Suite (iDatum) or 3rd party USB3 Vision Software		
Operating System	Windows, Linux,Arm		
Conformity	USB3 Vision, GenICam		

Contrastech LEO Series

Area Scan Cameras

Specifications



Model	LEO 2300S-40um/uc	LEO 5000S-35um/uc	LEO 5000A-45um/uc	LEO 5000P-72um/uc
Camera				
Resolution (H*V)	1920 × 1200	2448 × 2048	2592 × 1944	2592 × 2048
Sensor	SONY IMX249	SONY IMX264	Aptina AR0521	ON Semiconductor PYTHON5000
Sensor Size (optical)	1/1.2"	2/3"	1/2.5"	1"
Sensor Technology	CMOS, Global	CMOS, Global	CMOS, Rolling	CMOS, Global
Pixel Size [μm]	5.86 × 5.86	3.45 × 3.45	2.2 × 2.2	4.8 × 4.8
Frame Rate [fps]	Mono: 41 Color: 40	35.1	44.7	71.8
Data Bits	8bit / 10bit / 12bit	8bit / 10bit / 12bit	8bit / 10bit / 12bit	8bit / 10bit / 12bit
Exposure Time	34μs~10s	15μs~10s	28μs~0.6s	59μs~10s
Dynamic Range	70dB	72dB	60dB	<60dB
Color	Mono / Color	Mono / Color	Mono / Color	Mono / Color
Image Format	Mono: Mono8/10/10p/12/12p Color: Mono 8/10/12,Bayer RG 8/10/10p/12/12p (For LEO 2300S-40uc) Color: Mono 8/10/12,Bayer GB 8/10/10p/12/12p (For LEO 5000S-35uc) Color: Mono 8/10/12 Bayer GR 8/10/10p/12/12p (For LEO 5000A-45uc) Color: Mono 8/10/12,Bayer BG 8/10/10p/12/12p (For LEO 5000P-72uc)			
Interface	USB 3.0			
Synchronization	Via hardware trigger, via software trigger or free run			
Programmable Control [ISP]	Image Resolution, RGB gain, Exposure Time, Contrast, Gamma Chart, Image Rollover, Raw, LUT, Black Level Correction.			
Electrical				
Housing Size[L*W*H]	29.0×29.0×30.0 mm (55g) (*B)		29.0×29.0×30.0 mm (*B) Momo: (80g) Color: (55g)	29.0×29.0×30.0 mm (55g) (*B)
Operating Temperature	-30~70 ° C (Storage), 0~50° C (Working)			
Lens Mount	C-Mount			
Digital I/O	1 opto-isolated input, 1 opto-isolated output, 1 bidirectional custom non-isolation I/O			
Power Input	DC 12V, USB	DC 12V, USB	Mono:DC 9-24V, USB Color:DC 12V, USB	DC 12V, USB
Power Consumption	5V @<2.5W	5V @2.8W	5V @2.5W	5V @3.5W
Driver	LEO Series camera Software Suite (iDatum) or 3rd party USB3 Vision Software			
Operating System	Windows, Linux,Arm			
Conformity	USB3 Vision, GenICam			

Contrastech LEO Series

Area Scan Cameras



Specifications

Model	LEO 5000S-74um/uc	LEO 6000S-43um/uc	LEO 4020S-32um/uc	LEO 5470S-19ums
Camera				
Resolution (H*V)	2448 × 2048	3072 × 2048	4000×3036	5472 × 3648
Sensor	SONY IMX250	SONY IMX178	SONY IMX226	SONY IMX183
Sensor Size (optical)	2/3"	1/1.8"	1/1.7"	1"
Sensor Technology	CMOS, Global	CMOS, Rolling	CMOS, Rolling	CMOS, Rolling
Pixel Size [μm]	3.45 × 3.45	2.4 × 2.4	1.85 × 1.85	2.4 × 2.4
Frame Rate [fps]	74	42.7	31.9	19.2
Data Bits	8bit / 10bit / 12bit	8bit / 10bit / 12bit	8bit / 10bit / 12bit	8bit / 10bit / 12bit
Exposure Time	15μs~10s	Mono: 16μs~1s Color: 24μs~1s	Mono: 20μs~0.5s Color: 30μs~0.5s	28μs~0.7s
Dynamic Range	>75dB	>70dB	>70dB	>65dB
Color	Mono / Color	Mono / Color	Mono / Color	Mono
Image Format	Mono: Mono8/10/10p/12/12p Color: Mono 8/10/12,Bayer RG 8/10/10p/12/12p			
Interface	USB 3.0			
Synchronization	Via hardware trigger, via software trigger or free run			
Programmable Control [ISP]	Image Resolution, RGB gain, Exposure Time, Contrast, Gamma Chart, Image Rollover, Raw, LUT, Black Level Correction.			
Electrical				
Housing Size[L*W*H]	29.0×29.0×30.0 mm (80g) (*B)	29.0×29.0×30.0 mm (55g) (*B)	29.0×29.0×30.0 mm (80g) (*B)	
Operating Temperature	-30~70 ° C (Storage), 0~50° C (Working)			
Lens Mount	C-Mount			
Digital I/O	1 opto-isolated input, 1 opto-isolated output, 1 bidirectional custom non-isolation I/O			
Power Input	DC 9-24V, USB	DC 12V, USB	DC 9-24V, USB	DC 9-24V, USB
Power Consumption	5V @3.5W	5V @2.7W	5V @3W	5V @2.8W
Driver	LEO Series camera Software Suite (iDatum) or 3rd party USB3 Vision Software			
Operating System	Windows, Linux,Arm			
Conformity	USB3 Vision, GenICam			

Contrastech LEO Series

Area Scan Cameras



Specifications

Model	LEO 5470S-19um/uc	LEO 9MS-32um/uc	LEO 12MS-23um/uc
Camera			
Resolution (H*V)	5472 × 3648	4096 × 2160	4096 × 3000
Sensor	SONY IMX183	SONY IMX267	SONY IMX304
Sensor Size (optical)	1"	1"	1.1"
Sensor Technology	CMOS, Rolling	CMOS, Global	CMOS, Global
Pixel Size [μm]	2.4 × 2.4	3.45 × 3.45	3.45 × 3.45
Frame Rate [fps]	19.2	32	23.1
Data Bits	8bit / 10bit / 12bit	8bit / 10bit / 12bit	8bit / 10bit / 12bit
Exposure Time	Mono:28μs~0.7s Color:44μs~0.7s	50μs~10s	15μs~10s
Dynamic Range	>65dB	>72dB	>72dB
Color	Mono / Color	Mono / Color	Mono / Color
Image Format	Mono: Mono8/10/10p/12/12p Color: Mono 8/10/12,Bayer RG 8/10/10p/12/12p Color: Mono 8/10/12,Bayer GB 8/10/10p/12/12p (For LEO 5470S-19uc)		
Interface	USB 3.0		
Synchronization	Via hardware trigger, via software trigger or free run		
Programmable Control [ISP]	Image Resolution, RGB gain, Exposure Time, Contrast, Gamma Chart, Image Rollover, Raw, LUT, Black Level Correction.		
Electrical			
Housing Size[L*W*H]	44.0×29.0×60.0 mm (100g) (+C2)		
Operating Temperature	-30~70 ° C (Storage), 0~50° C (Working)		
Lens Mount	C-Mount		
Digital I/O	1 opto-isolated input, 1 opto-isolated output, 1 bidirectional custom non-isolation I/O		
Power Input	DC 12V, USB	DC 12V, USB	DC 12V, USB
Power Consumption	5V @2.8W	5V @<3.2W	5V @3.5W
Driver	LEO Series camera Software Suite (iDatum) or 3rd party USB3 Vision Software		
Operating System	Windows, Linux,Arm		
Conformity	USB3 Vision, GenICam		

Contrastech LEO Series

Area Scan Cameras

Specifications



Model	LEO 5000S-140cm/cc	LEO 1200S-70cm/cc
Camera		
Resolution (H*V)	2432 × 2048	3840 × 3000
Sensor	SONY IMX250	SONY IMX253
Sensor Size (optical)	2/3"	1.1"
Sensor Technology	CMOS, Global	CMOS, Global
Pixel Size [μm]	3.45 × 3.45	3.45 × 3.45
Frame Rate [fps]	140	Mono: 69.8 Color : 68.1
Data Bits	8bit / 10bit / 12bit	8bit / 10bit / 12bit
Exposure Time	Mono: 15μs~10s Color : 4μs~10s	1μs~10s
Dynamic Range	>75dB	>71dB
Color	Mono / Color	Mono / Color
Image Format	Mono: Mono8/10/12 Color: Bayer RG 8/10/12, RGB8	Mono: Mono8/10/12 Color: Bayer RG 8/10/12,RGB 8
Interface	Camera Link (Base : 2 Taps Medium : 4 Taps Full : 8 Taps 80-bit : 10 Taps)	
Synchronization	Via hardware trigger, via software trigger or free run	
Programmable Control [ISP]	Image Resolution, RGB gain, Exposure Time, Contrast, Gamma Chart, Image Rollover, Raw, LUT, Black Level Correction.	
Electrical		
Housing Size[L*W*H]	44.0×29.0×59.0 mm (100g) (*E)	
Operating Temperature	-30~70 ° C (Storage), 0~50° C (Working)	
Lens Mount	C-Mount	C-mount
Digital I/O	1 opto-isolated input, 1 opto-isolated output, 1 bidirectional custom non-isolation I/O, CameraLink provided IO	1 opto-isolated input, 1 opto-isolated output, 1 bidirectional custom non-isolation I/O
Power Input	DC 9-24V	DC 9-24V
Power Consumption	12V @<3.2W	12V @<4.7W
Driver	LEO Series camera Software Suite (iDatum) or Frame Grabber Software Conforming to GenICam Protocol	
Operating System	Windows	
Conformity	Cameralink,GenICam	

Contrastech LEO Series

Area Scan Cameras

Specifications



Model	LEO 29MK-5cm	LEO 43MK-4cm	LEO 50MK-4cm
Camera			
Resolution (H*V)	6576 × 4384	8032 × 5360	10440 × 4800
Sensor	KAI-29050	KAI-43140	KAI-50140
Sensor Size (optical)	36mm × 24mm	36mm × 24mm	46.98mm × 21.60mm
Sensor Technology	CCD, Global	CCD, Global	CCD, Global
Pixel Size [μm]	5.5 × 5.5	4.5 × 4.5	4.5 × 4.5
Frame Rate [fps]	4.5	3.6	4
Data Bits	8bit / 10bit / 12bit	8bit / 10bit / 12bit	8bit / 10bit / 12bit
Exposure Time	103μs~2s	100μs~2s	102μs~10s
Dynamic Range	64dB	60dB	60dB
Color	Mono (Divided into high and low level sensors)	Mono	Mono
Image Format	Mono8/10/12	Mono8/10/12	Mono8/10/12
Interface	Camera Link (Base:1 Tap,2 Taps Medium:4 Taps)	Camera Link (Base:2 Taps Medium:4 Taps)	
Synchronization	Via hardware trigger, via software trigger or free run		
Programmable Control [ISP]	Image Resolution, Exposure Time, Contrast, Gamma Chart, Image Rollover, Raw, LUT, Black Level Correction.		
Electrical			
Housing Size[L*W*H]	M58 :(Air-cooling) 74.0×74.0×74.1 mm (*L) F :(Air-cooling) 74.0×74.0×80.5 mm (*M)	F:(Standard) 86.0×86.0×87.3 mm (*N)	M58:(Standard) 86.0×86.0×87.2 mm (*O)
Operating Temperature	-30~70 ° C (Storage), 0~50° C (Working)		
Lens Mount	M58 / F-mount	F-mount	M58
Digital I/O	1 opto-isolated input, 1 opto-isolated output, 1 bidirectional custom non-isolation I/O, 1 RS232,1 RS485	1 opto-isolated input, 1 opto-isolated output, 1 RS232	
Power Input	DC 12V	DC 22-26V	
Power Consumption	12V @<11W	24V @<60W(Cooling) 24V @<16W(Non-Cooling)	24V @<70W(Cooling) 24V @<18W(Non-Cooling)
Driver	LEO Series camera Software Suite (iDatum) or Frame Grabber Software Conforming to GenICam Protocol		
Operating System	Windows		
Conformity	Cameralink,GenICam		

Contrastech LEO Series

Area Scan Cameras

Specifications



Model	LEO 31MS-18xm-F	LEO 43MS-16xm-F	LEO 65MG-31xm	LEO 150MS-6xc-M72
Camera				
Resolution (H*V)	6464 × 4852	7904 × 5432	9216 × 7000	14208 × 10640
Sensor	SONY IMX342	GMAX0806	GMAX3265	SONY IMX411
Sensor Size (optical)	APS-C	22.16mm × 15.22mm	29.9mm × 22.4mm	66.7mm
Sensor Technology	CMOS, Global	CMOS, Global	CMOS, Global	CMOS, Rolling
Pixel Size [μm]	3.45 × 3.45	2.8 × 2.8	3.2 × 3.2	3.75 × 3.75
Frame Rate [fps]	17.9	16.35	31.5	6.2
Data Bits	8bit / 10bit / 12bit	8bit / 10bit / 12bit	8bit / 10bit / 12bit	8bit / 10bit / 12bit / 16bit
Exposure Time	47μs~2s	12μs~2s	14μs~10s	15μs~10s
Dynamic Range	>72dB	<70dB	>66dB	>78dB
Color	Mono	Mono	Mono	Color
Image Format	Mono8/10/12			Mono 8/10/12/16, Bayer RG8/10/12/16,RGB 8
Interface	CoaXPRESS			
Synchronization	Via hardware trigger, via software trigger or free run			
Programmable Control [ISP]	Image Resolution, RGB gain, Exposure Time, Contrast, Gamma Chart, Image Rollover, Raw, LUT, Black Level Correction.			
Electrical				
Housing Size[L*W*H]	F:(Air-cooling) 74.0×74.0×75.6 mm (*P)	M58:(Air-cooling) 74.0×74.0×70.8 mm (*X) F:(Air-cooling) 74.0×74.0×76.8 mm (*Y)	M58:(Air-cooling) 74.0×74.0×70.4 mm (*Q) F:(Air-cooling) 74.0×74.0×76.4 mm (*R)	100×100×74.3 mm(*Z)
Operating Temperature	-30~80 ° C (Storage), 0~50° C (Working)			
Lens Mount	F-mount		F-mount / M58	M72
Digital I/O	1 opto-isolated input, 1 opto-isolated output, 1 bidirectional custom non-isolation I/O, 1 RS232			
Power Input	DC 9-24V			DC 12-24V
Power Consumption	12V @9W	12V @7W	12V @12W	24V @<21W
Driver	Frame Grabber Software Conforming to CoaXPRESS Protocol			
Operating System	Windows			
Conformity	CoaXPRESS			

Contrastech LEO Series

Area Scan Cameras

Specifications



Model	LEO 12MS-68tgm	LEO 25MP-40tgm	LEO 25MP-40tgc
Camera			
Resolution (H*V)	4096 × 3000	5120 × 5120	5120 × 5120
Sensor	SONY IMX253	ON Semiconductor PYTHON25K	ON Semiconductor PYTHON25K
Sensor Size (optical)	1.1"	23mm × 23mm	23mm × 23mm
Sensor Technology	CMOS, Global	CMOS, Global	CMOS, Global
Pixel Size [μm]	3.45 × 3.45	4.5 × 4.5	4.5 × 4.5
Frame Rate [fps]	68	40	40
Data Bits	8bit / 10bit / 12bit	8bit / 10bit / 12bit	8bit / 10bit / 12bit
Exposure Time	2μs~10s	45μs~10s	45μs~10s
Dynamic Range	>71dB	58dB	58dB
Color	Mono	Mono	Color
Image Format	Mono 8/10/10p/12/12p	Mono 8/10/10p/12/12p	Mono 8/10/12, Bayer RG 8/10/10p/12/12p
Interface	10 GigE	10 GigE	10 GigE
Synchronization	Via hardware trigger, via software trigger or free run		
Programmable Control [ISP]	Image Resolution, RGB gain, Exposure Time, Contrast, Gamma Chart, Image Rollover, Raw, LUT, Black Level Correction.		
Electrical			
Housing Size[L*W*H]	M58:(Air-cooling) 74.0×74.0×72.4 mm (*S) F:(Air-cooling) 74.0×74.0×78.4 mm (*T)	M58:(Air-cooling) 74.0×74.0×72.7 mm (*J) F:(Air-cooling) 74.0×74.0×78.7 mm (*K)	
Operating Temperature	-30~80 ° C (Storage), 0~50° C (Working)		
Lens Mount	F-mount / M58		
Digital I/O	1 opto-isolated input, 1 opto-isolated output, 1 bidirectional custom non-isolation I/O, 1 RS232		
Power Input	DC 12-24V	DC 9-16V	DC 9-16V
Power Consumption	12V @<11W	12V @<14W	12V @<14W
Driver	LEO Series camera Software Suite (iDatum) or 3rd party GigE Vision Software		
Operating System	Windows, Linux		
Conformity	GigE Vision		

Contrastech LEO Series

Area Scan Cameras

Housing Size(mm)

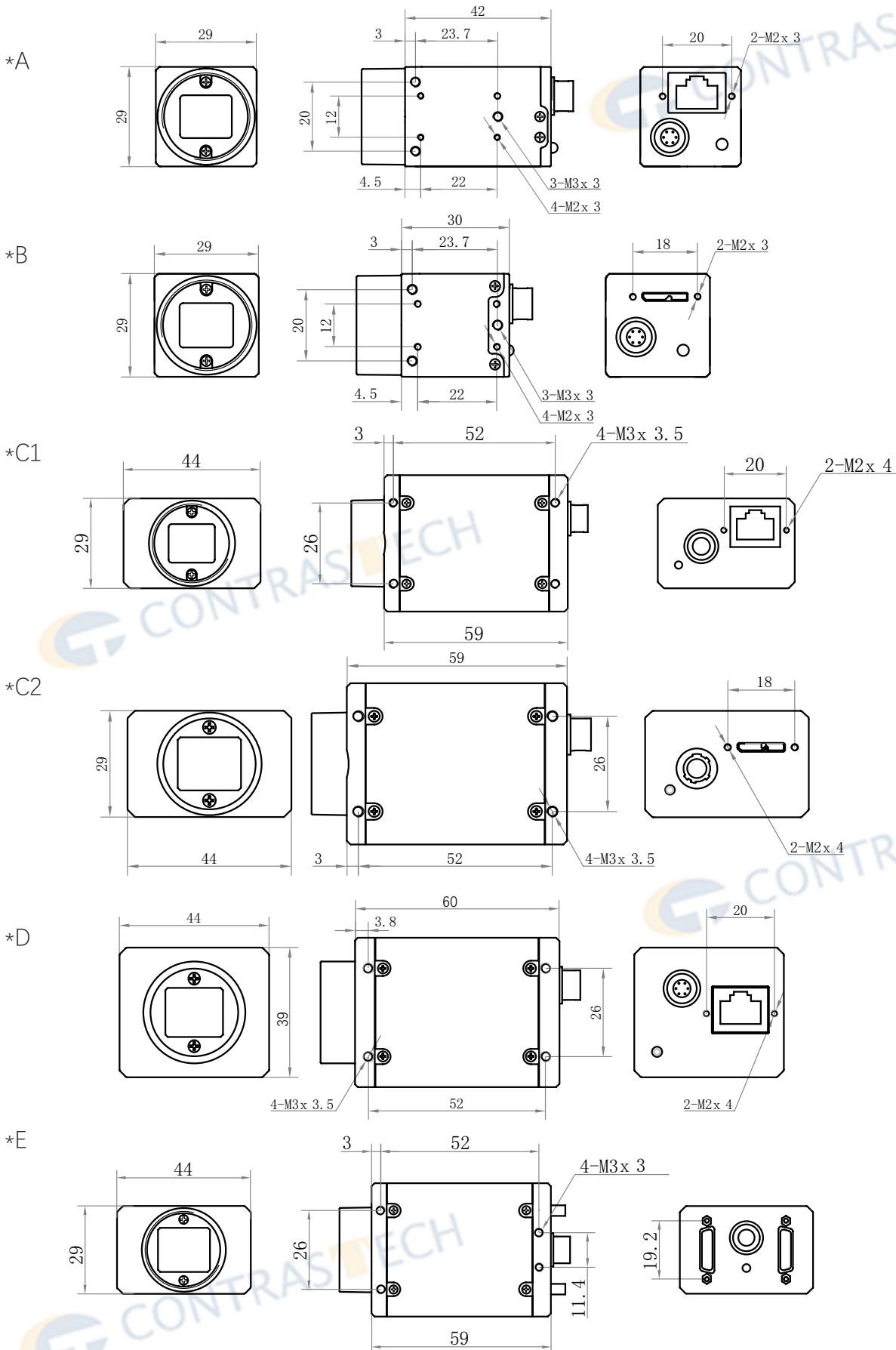

Contrastech LEO Series

Area Scan Cameras

Housing Size(mm)

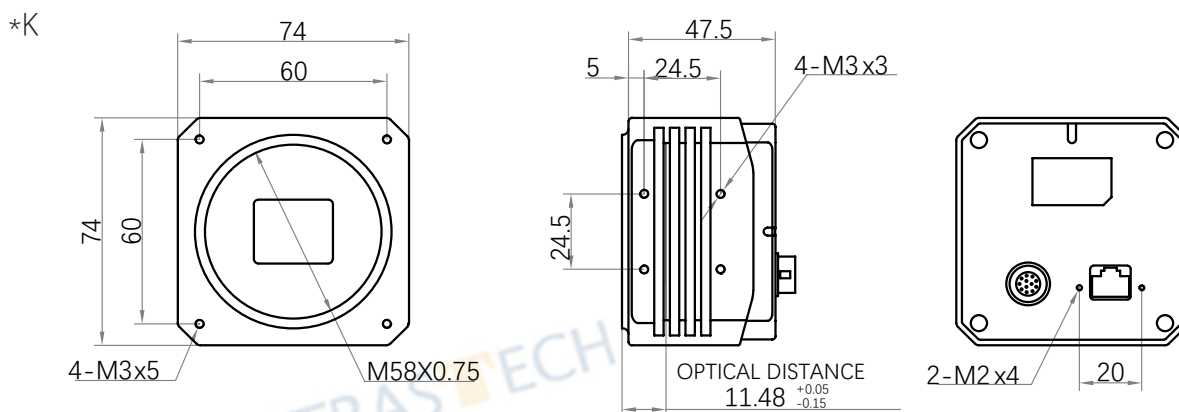
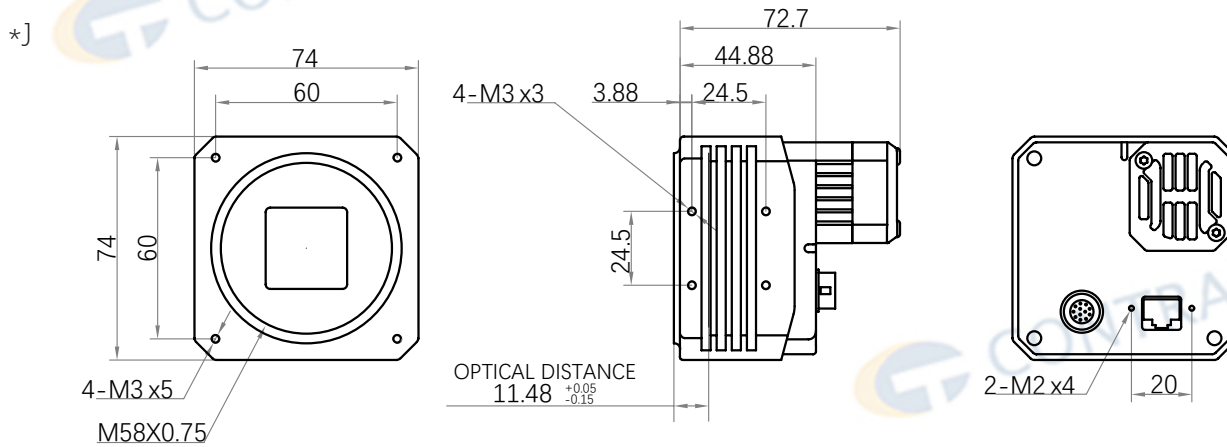
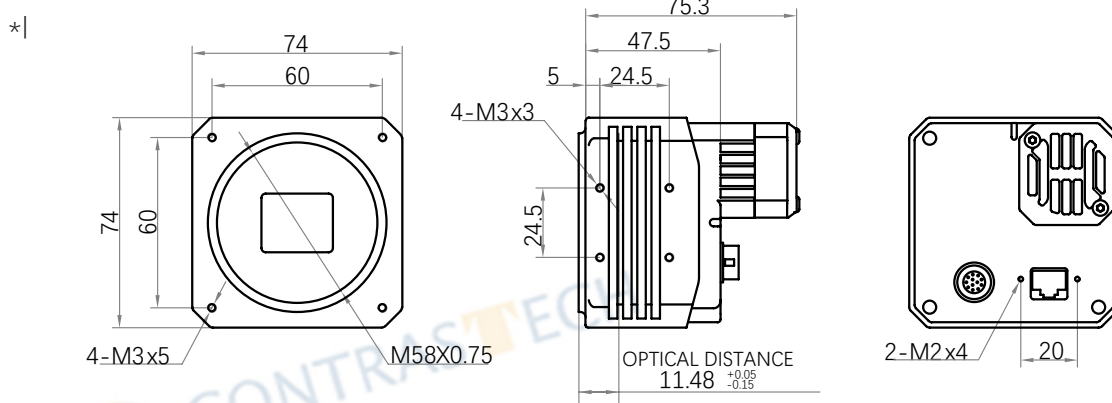
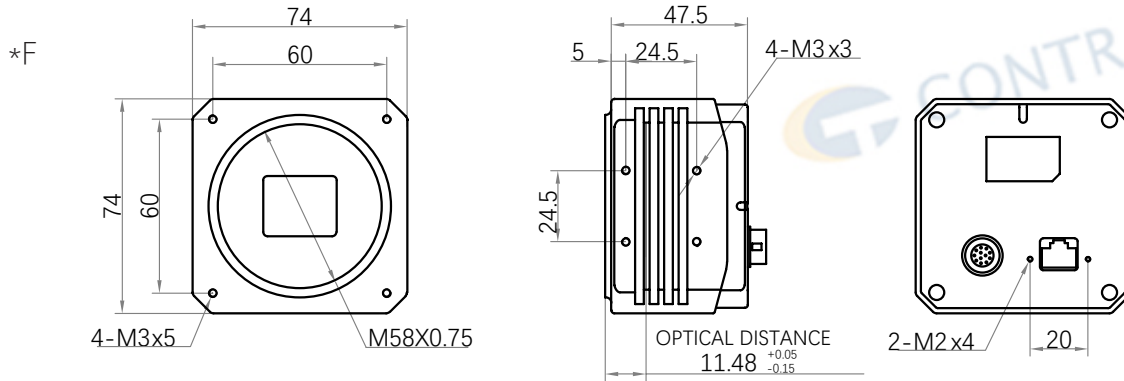

Contrastech LEO Series

Area Scan Cameras

Housing Size(mm)

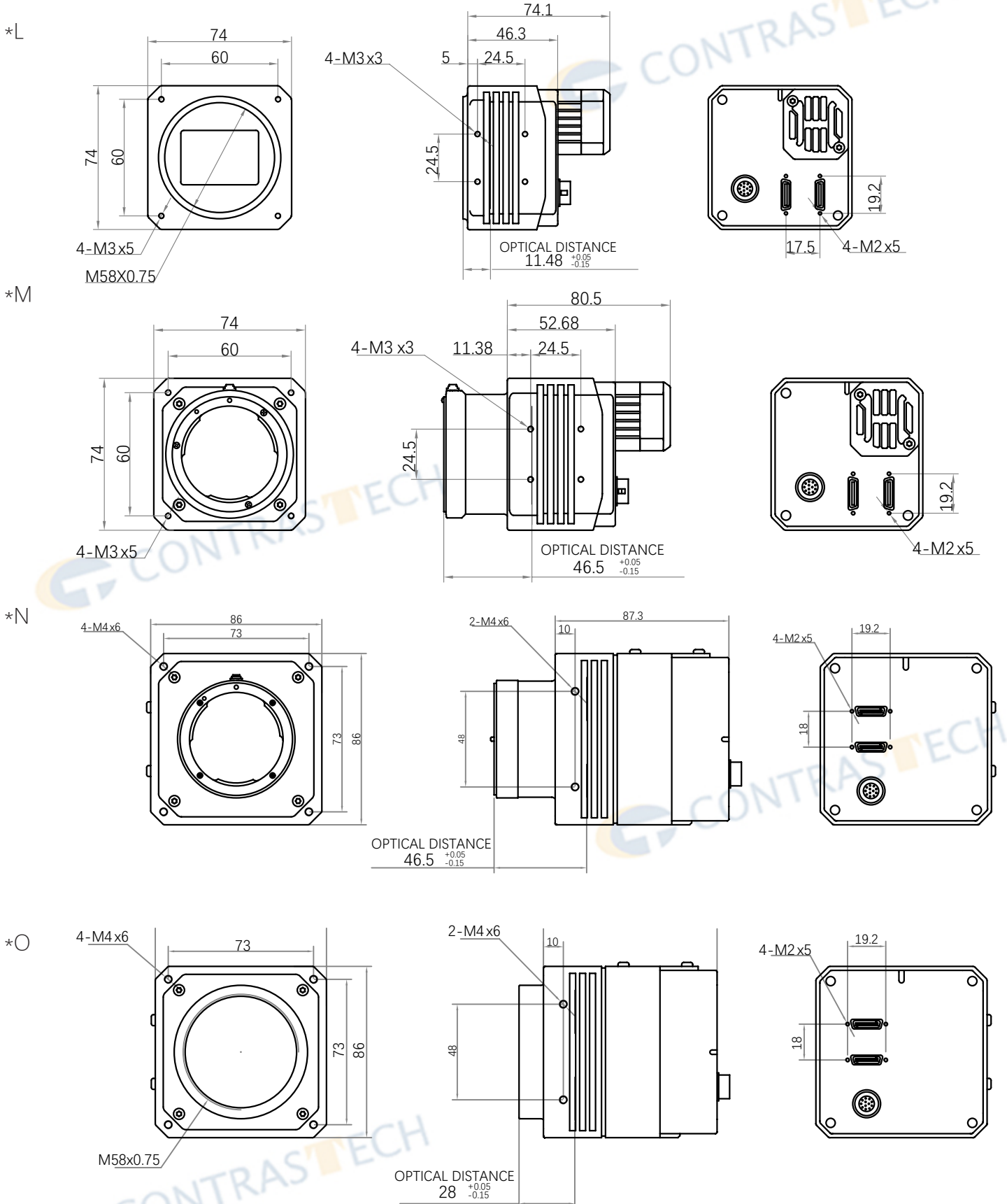

Contrastech LEO Series

Area Scan Cameras

Housing Size(mm)

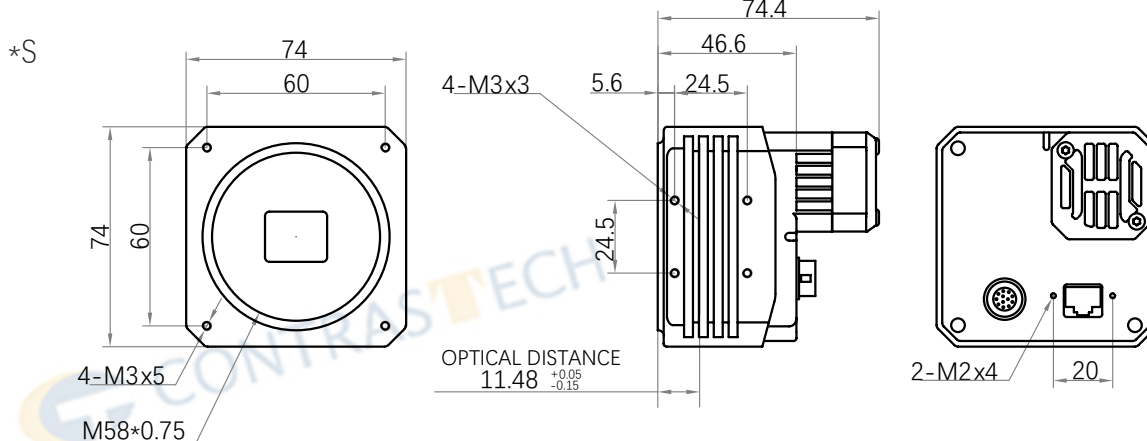
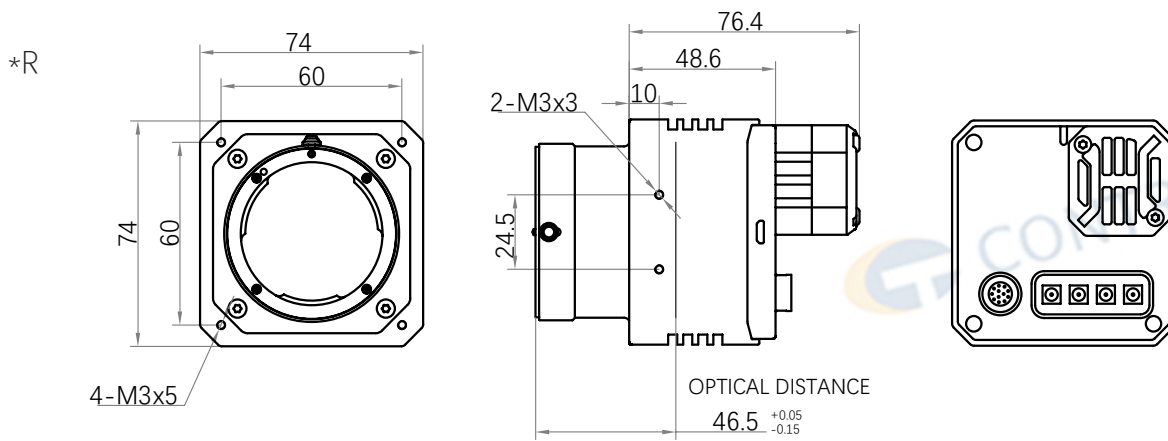
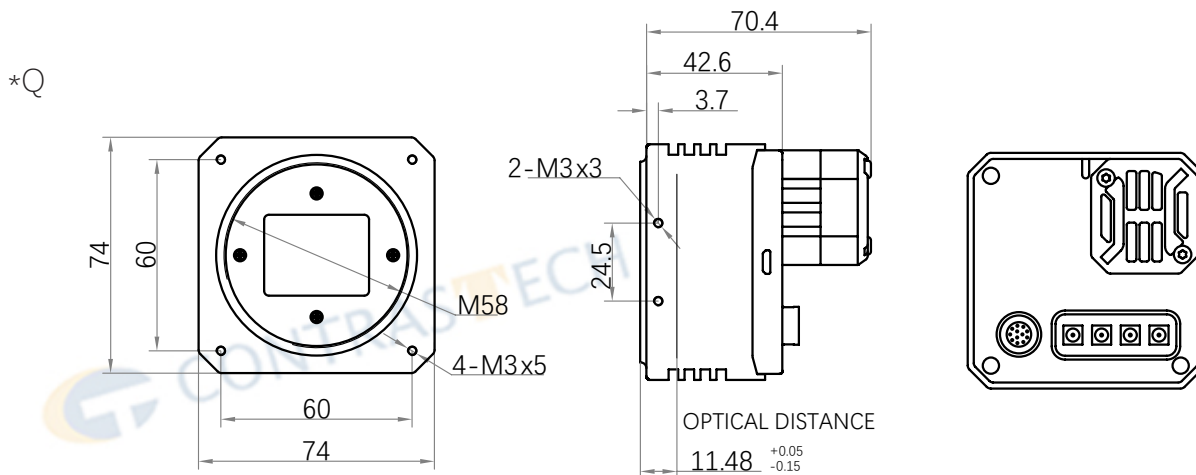
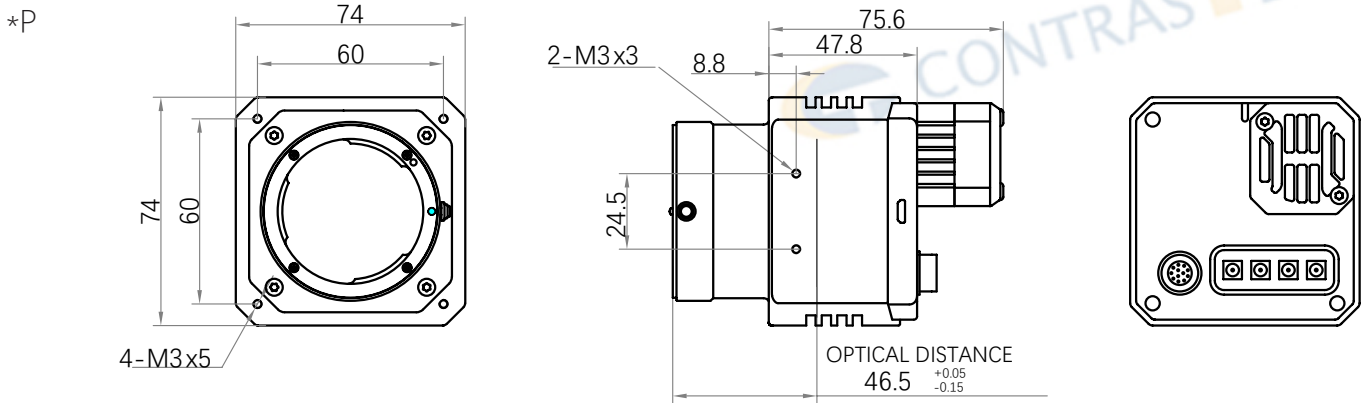

Contrastech LEO Series

Area Scan Cameras

Housing Size(mm)

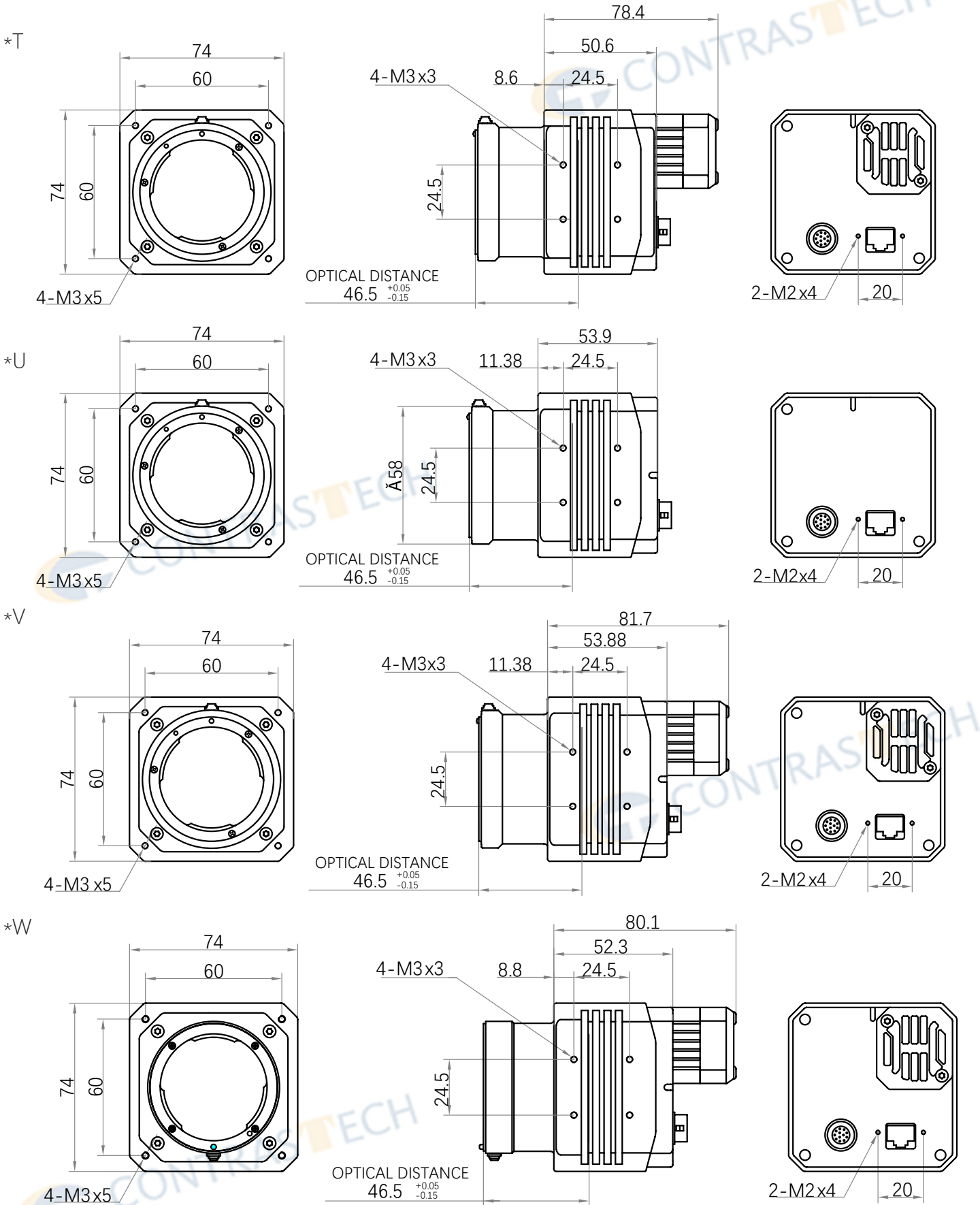

Contrastech LEO Series

Area Scan Cameras

Housing Size(mm)

*X

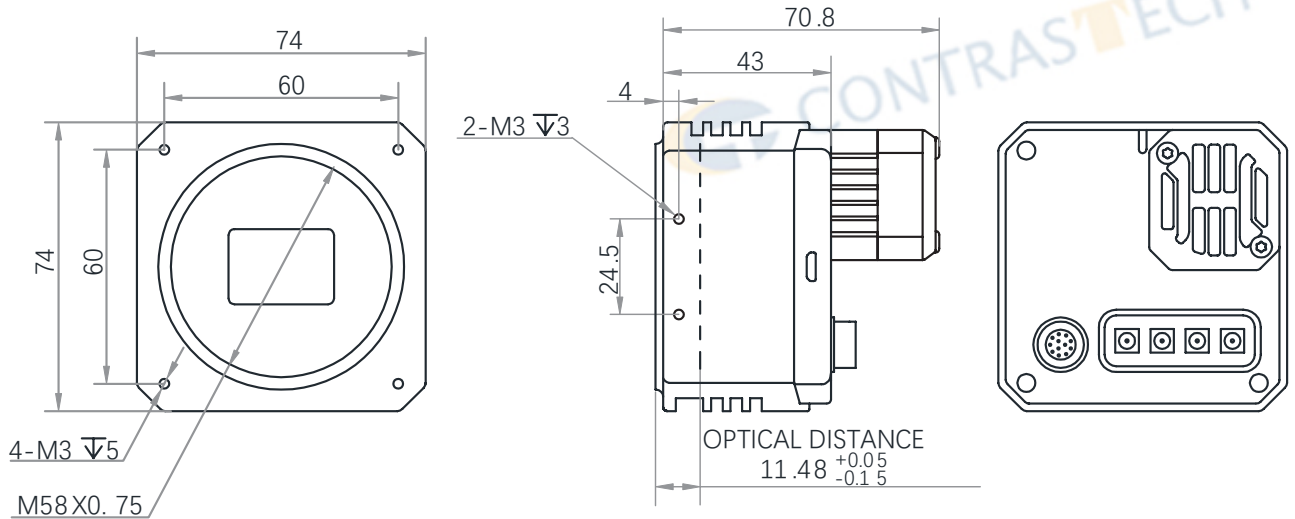

*Y

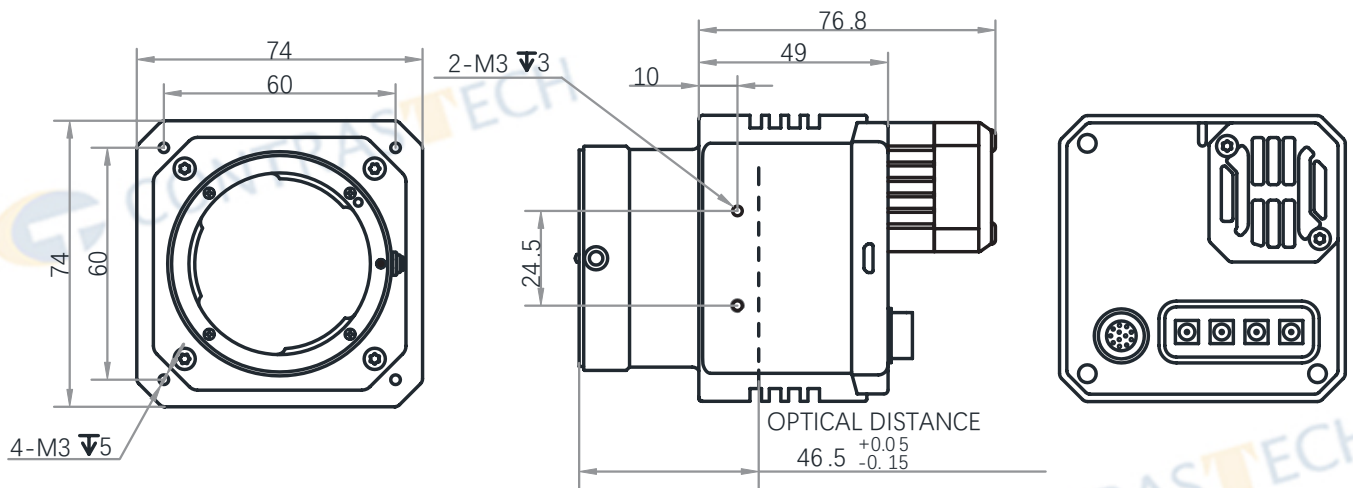

*Z

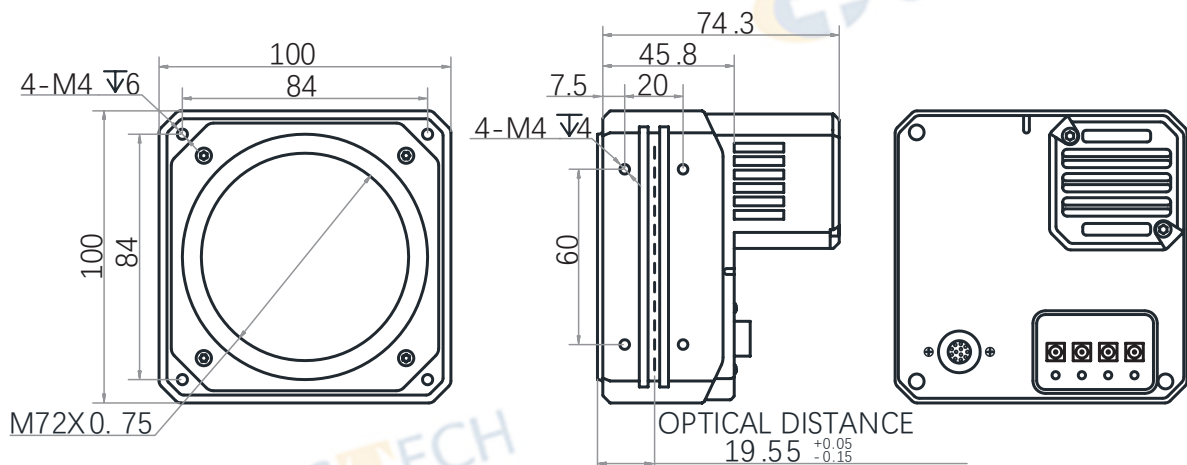

ABOUT US

Contrastech provides free of charge consulting about lenses, illumination, optical components and Industrial Cameras.

As one high-tech enterprise, Hangzhou Contrastech Co., Ltd. specializes in providing professional machine vision software, hardware and equipment. Contrastech has been researching and developing machine vision applications, and the major products include industrial camera, scientific standard camera, high definition frame grabber card, industrial FA lens, telecentric lens, machine vision lights and image processing software.

The Engineering Dept. of Contrastech have lots of mature and successful machine vision solutions based on automatic industrial inspection, high precision measuring and module distinguishing.

Contrastech's portfolio of products offers customers the vision industry's widest selection of industrial and network cameras as well as lenses. Today it includes more than 200 camera

models – and it's still growing. We're committed to developing technology that drives business results for our customers: cameras and lenses that are easy to use, easy to integrate, and deliver an outstanding price/performance ratio.



CONTACT US

Company: Hangzhou Contrastech Co.,Ltd
Add.: Xiyuan 9th Road West Lake District, Hangzhou 310030 China
Tel.: +86 0571-89712238
Email: market@contrastech.com (Market)
support@contrastech.com (Support)
Web site: www.contrastech.com

